

StorEdge™ Solution Applications with the StorEdge Inverter and LG Chem Batteries – Connection and Configuration (North America)

SolarEdge’s StorEdge Solution can be used for various applications that enable energy independence for system owners, by utilizing a battery to store power and supply power as needed. The StorEdge Solution is based on and managed by the SolarEdge inverter for both PV and battery management and is compatible with LG Chem High Voltage RESU 10H Battery.

This document explains how to set up your StorEdge system to work in different configurations.

Contents

StorEdge™ Solution Applications with the StorEdge Inverter and LG Chem Batteries – Connection and Configuration (North America).....	1
Revision History	2
Overview	2
StorEdge Operation Modes	2
System Components	5
System Configurations	6
Compatibility Information.....	7
Related Documentation	7
Smart Energy Management with Backup Power - System Configurations	8
System Connection	8
Basic Configuration	11
Large Residential PV Systems	14
Additional Capacity with Two Batteries.....	16
Additional Capacity and Power with Multiple Inverters.....	17
AC Coupling using a non-SolarEdge Inverter	18
Backup Power Only - System Configurations.....	20
System Connection	20
Basic Configuration	23
Large Residential PV Systems	26
Additional Capacity with Two Batteries.....	27
Additional Capacity and Power with Multiple Inverters.....	28
AC Coupling using a non-SolarEdge Inverter	29
Smart Energy Management Only - System Configurations.....	31
System Connection	31
Basic Configuration	34
Large Residential PV Systems	34
Additional Capacity with Two Batteries.....	36
Additional Capacity and Power with Multiple Inverters.....	37
AC Coupling using a non-SolarEdge Inverter	38
Appendix A – Creating a Charge/Discharge Profile.....	40
Charge/Discharge Modes.....	40
Creating a Profile	40
Appendix B – Verifying StorEdge Functionality.....	41
Appendix C – StorEdge Inverter without a Battery.....	42
Appendix D – Check Number of RS485 Buses.....	43
Appendix E – Detailed System Connection Drawings	44
Smart Energy Management with Backup Power – Basic Configuration	44
Smart Energy Management with Backup Power – Basic Configuration (2 Battery)	47
Smart Energy Management with Backup Power – Basic Configuration (Two Inverters and Two Batteries).....	50
Appendix F - Powering the LG Chem Battery off and on	53
SolarEdge Support Contact Information	54

Revision History

- Version 2.2 (November 2018)
 - Added a requirement to perform a battery self-test in each configuration.
 - Added *Appendix F - Powering the LG Chem Battery off and on* on 53.
- Version 2.1 – removed Tesla battery thermal connection
- Version 2.0 – removed Tesla batteries, added LG batteries
- Version 1.0 – initial version, using Tesla batteries

Overview

StorEdge Operation Modes

The StorEdge Inverter solution can be used in three different operating modes, described in the following sections:

- Smart Energy Management with Backup Power
- Backup Power Only
- Smart Energy Management Only

In addition to the above-mentioned modes, the StorEdge inverter can be used as a PV inverter without using StorEdge battery-based applications.

**NOTE**

For configuring the inverter when not using any StorEdge applications, refer to *Appendix C – StorEdge Inverter without a Battery*.

**NOTE**

The StorEdge inverter requires CPU version 3.18xx and above. If an upgrade is required contact SolarEdge support for an upgrade file and instructions.

All modes can be used together with the export limitation application. For details on export limitation, refer to http://www.solaredge.com/files/pdfs/export_limitation_application_note_NA.pdf.

Smart Energy Management with Backup Power

This combined mode allows use some of the stored energy for backup power and the rest for smart energy management applications. The StorEdge inverter monitors the grid, and when there is a power outage, it automatically switches to backup mode, disconnecting from the grid and supplying power to backed-up loads.

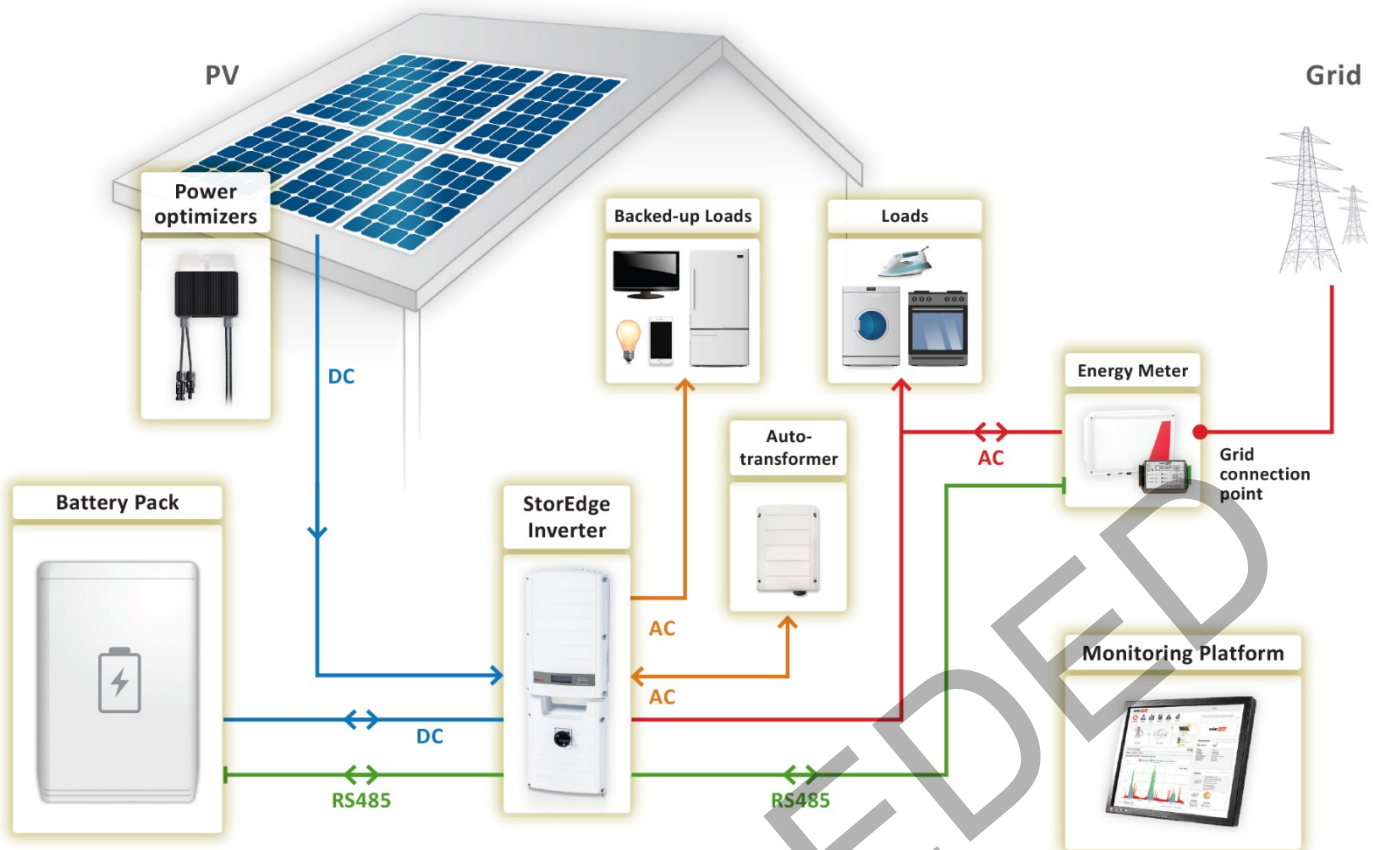

Figure 1: Smart Energy Management with Backup Power

SUPERSEDED

Backup Power Only

This mode is used to store energy for backup power only. The StorEdge inverter monitors the grid, and when the grid is down it automatically switches to backup mode, disconnecting from the grid and supplying power to backed-up loads. In cases where battery charging from the grid is permitted, this mode can be used without PV modules.

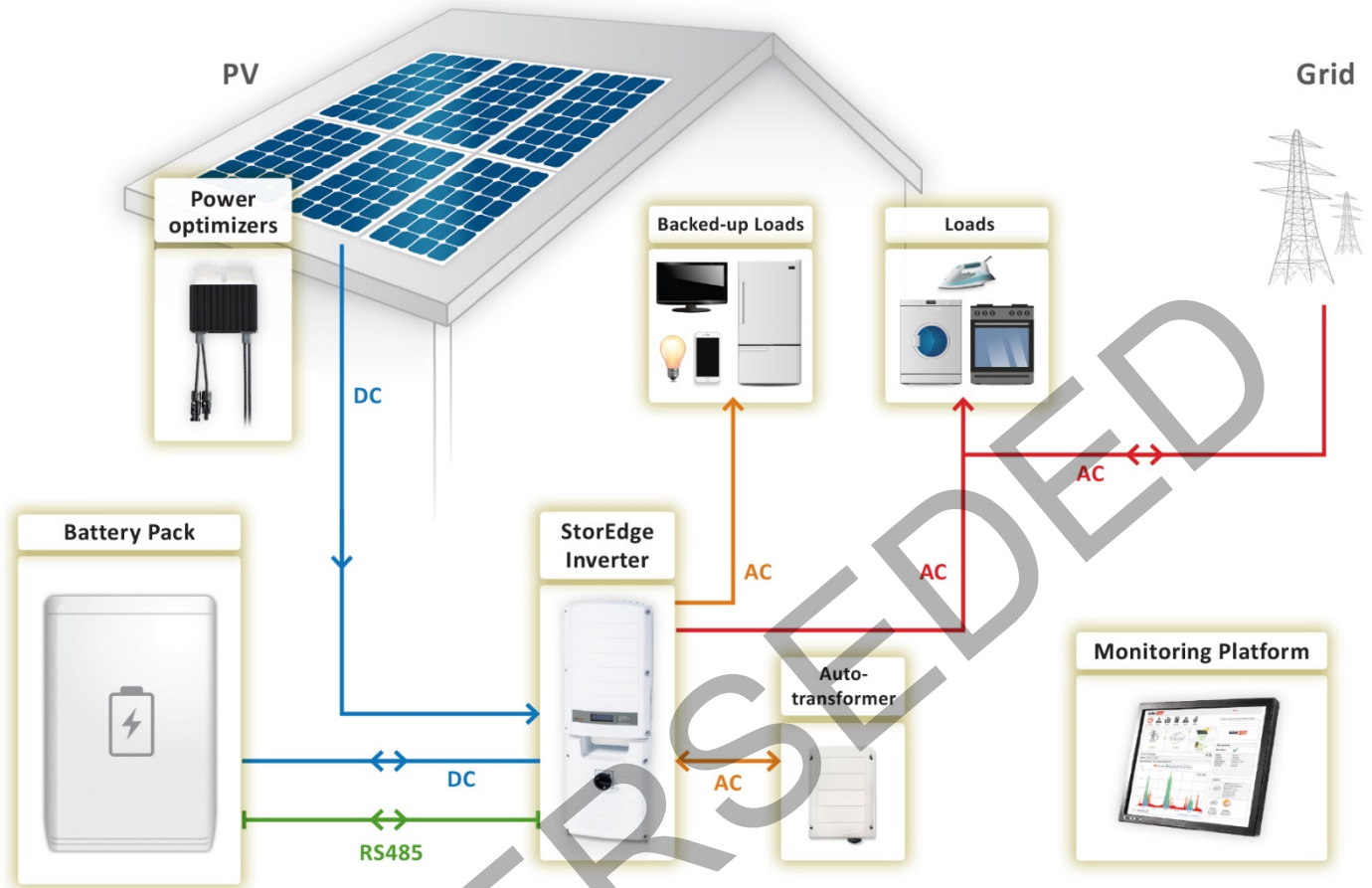

Figure 2: Backup Power only

SUPERSEDED

Smart Energy Management Only

In this mode, PV-generated energy is stored for use in smart energy management applications:

- **Maximize self-consumption.** In this application, the battery is automatically charged and discharged to meet consumption needs and reduce the amount of electricity purchased from the grid.
- **Charge/discharge profile programming.** In this application, the system operates according to a configurable charge/discharge profile – for example, a time-of-use arbitrage profile, in which the battery is charged from the PV system or grid when tariffs are low, and discharged when tariffs are high.



NOTE

In cases where battery charging from the grid is permitted, this mode can be used without PV modules.

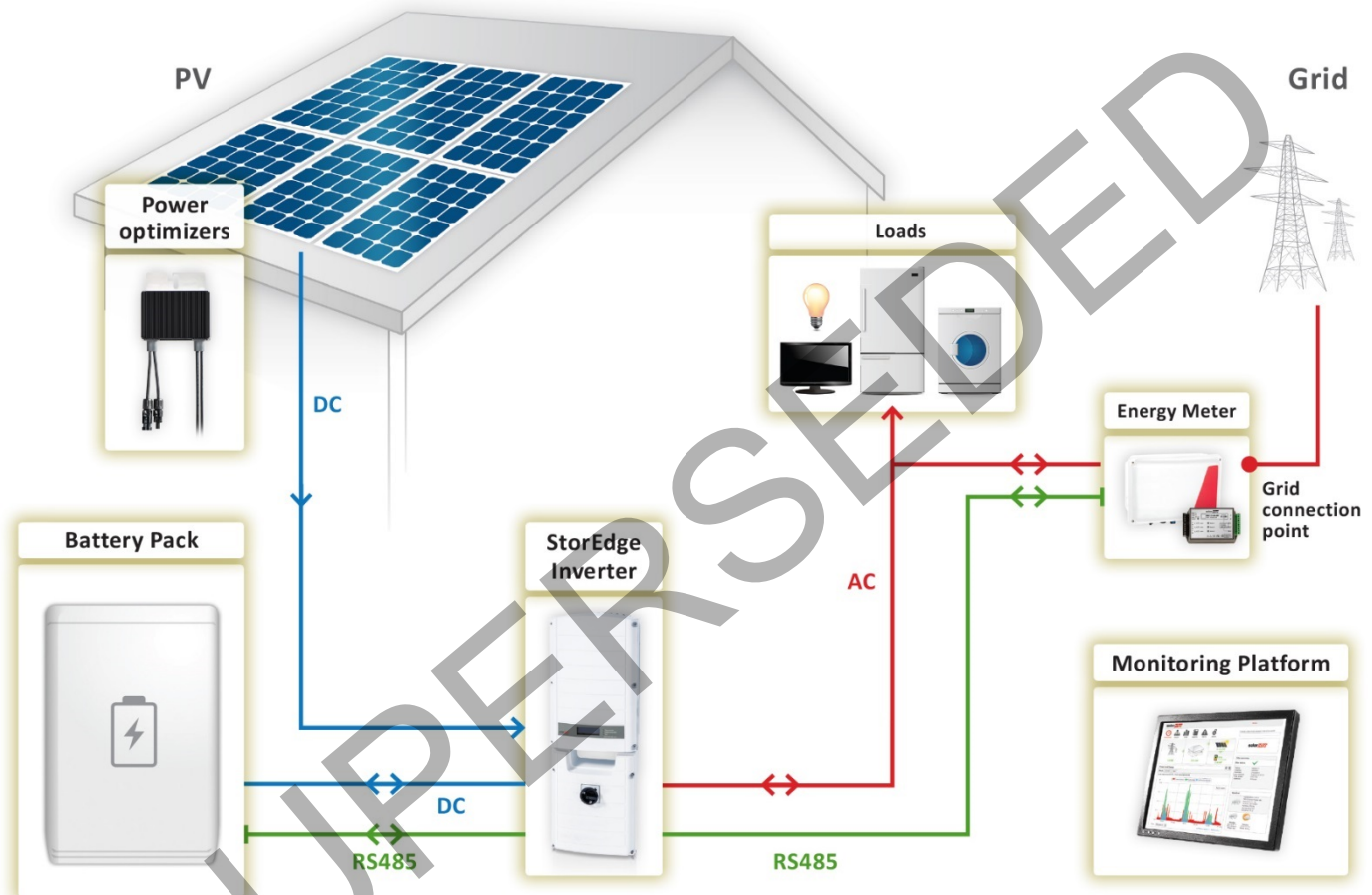

Figure 3: Smart Energy Management only

System Components

The StorEdge Solution is comprised of the following components:

- **StorEdge Inverter**– the single phase StorEdge inverter manages battery and system energy in addition to its traditional functionality as a DC-optimized PV inverter.



NOTE

A revenue grade StorEdge Inverter with Backup is available. It includes a built-in revenue grade meter that measures inverter production.

- **Auto-transformer** – The auto-transformer is used for phase balancing only in case of backup power. It receives 240V output from the inverter and splits and balances output to supply power supplies to 120V backed-up loads. The auto-transformer is not required if the system is operated in Smart Energy Management mode when no backup power is needed.
- **SolarEdge Energy Meter** – the meter is used by the inverter for import/export or consumption readings, and manages the battery charge/discharge for Smart Energy Management applications in accordance with the readings. The meter readings are displayed in the SolarEdge monitoring portal. The meter is optional for Backup Power Only mode.

- **Backed-up loads panel** – loads that should be supplied with backup power in case of a power outage should be wired through a separate load panel. In systems with multiple StorEdge inverter, a backed-up loads panel is required for each inverter.
- **Optional: RS485 Plug-in** – the kit is used for systems with more than one SolarEdge inverter where the inverter connected to the battery has only a single RS485 bus, or systems with a third-party controller. The kit provides an additional RS485 port within the inverter for connection. For instructions on how to check if the inverter has a single RS485 bus or two, refer to *Appendix D – Check Number of RS485 Buses*.
- **LG Chem RESU10H Battery** – a DC-coupled battery designed to work with the StorEdge solution.

System Configurations

The configurations described in the application note are the following:

Use Case	Description
Basic Configuration	In a basic configuration, one of each of the above-described StorEdge components is installed in accordance to the system operation mode; the auto-transformer is not required if the system is operated in Smart Energy Management mode and the meter is optional for Backup Power Only mode. This configuration is suitable for most residential systems.
Large Residential PV Systems	For residential sites with large PV systems, a StorEdge inverter and a SolarEdge single phase inverter may be installed together. The StorEdge inverter manages the battery and functions as a PV inverter, and the second inverter is used for production of the additional PV power. During power outages, the StorEdge inverter provides power to backed-up loads, and the second inverter remains shut down until grid power is restored.
Additional Capacity with Two Batteries ¹	For sites where additional battery capacity is needed (for example, to enable backed-up loads to be powered from the battery for longer periods), two batteries may be connected to a single StorEdge inverter. In this configuration, only one battery operates at any given time – i.e. the two batteries provide additional capacity only, not additional power.
Additional Capacity and Power with Multiple Inverters²	For sites where additional capacity and power with multiple inverters is needed (for example, to enable more backed-up loads to be powered simultaneously). In this case two StorEdge inverters, each connected to the PV, and two batteries may be installed. Each battery connects through a separate StorEdge Inverter, and each inverter manages the battery and the PV connected to it. Backed-up loads are connected to each inverter through separate load panels and auto-transformers. The inverter connected to the meter operates as the system manager.
AC Coupling using a non-SolarEdge Inverter	For sites with an already-installed PV system with a non-SolarEdge inverter, the StorEdge inverter can be AC-coupled to the existing inverter, i.e. the StorEdge inverter used to manage the battery is connected to the AC output of the existing inverter and charges the battery using the PV power produced by the non-SolarEdge inverter. In case the system is in backup, the non-SolarEdge inverter will not stay on.

¹ When connecting two LG Chem batteries, each battery must have a different part number; supporting SolarEdge firmware required – CPU version 3.2305 and above

² Additional capacity and power with multiple inverters requires CPU version 3.2305 and above

Compatibility Information

The following table lists the StorEdge applications that can be used for each system configuration:

System Configuration	Smart Energy Management Applications			
	Maximize Self-consumption	Charge/Discharge Profile Programing	Zero Export Limitation	Non-Zero Export Limitation
Basic Configuration	✓	✓	✓	✓
Large Residential PV Systems	✓	✓	✓	✓
Additional Capacity with Two Batteries	✓	✓	✓	✓
Additional Capacity and Power with Multiple Inverters	✓	✓	✓	✓
AC Coupling using a non-SolarEdge Inverter	✓			✓

Related Documentation

For detailed installation and configuration instructions of the system components refer to the following installation guides:

Inverter installation:

- StorEdge Solution Installation Guide:
https://www.solaredge.com/sites/default/files/storedge_backup_installation_guide_NA.pdf
- Electricity meter installation:
<https://www.solaredge.com/sites/default/files/solaredge-meter-installation-guide-na.pdf>
- Wiring guide and onsite checklist:
https://www.solaredge.com/sites/default/files/storedge_wiring_quick_guide_and_on_site_checklist_na.pdf
- Charge/discharge profile programming:
https://www.solaredge.com/sites/default/files/storedge_charge_discharge_profile_programming.pdf
- Export limitation:
https://www.solaredge.com/sites/default/files/feed-in_limitation_application_note.pdf

Smart Energy Management with Backup Power - System Configurations

In this mode, some of the battery energy is reserved for backup power and the rest can be used for Smart Energy Management applications. In case of a power outage, the inverter automatically switches to backup mode, disconnecting from the grid and supplying power to backed-up loads.

For configurations with more than one SolarEdge inverter, the inverters are connected to each other with RS485, with one inverter configured as the master and connected to the SolarEdge monitoring server. If the master inverter has a single RS485 bus, an RS485 Plug-in should be installed in the inverter for connection of the meter on a second RS485 bus. For instructions on how to check if the inverter has a single RS485 bus or two, refer to *Appendix D – Check Number of RS485 Buses*.

System Connection

The following diagram illustrates the connection of the system components when using the basic configuration for Smart Energy Management with backup power: one StorEdge inverter, one auto-transformer, one meter and one battery. For enlarged segments of this diagram, refer to *Appendix E – Detailed System Connection Drawings*.

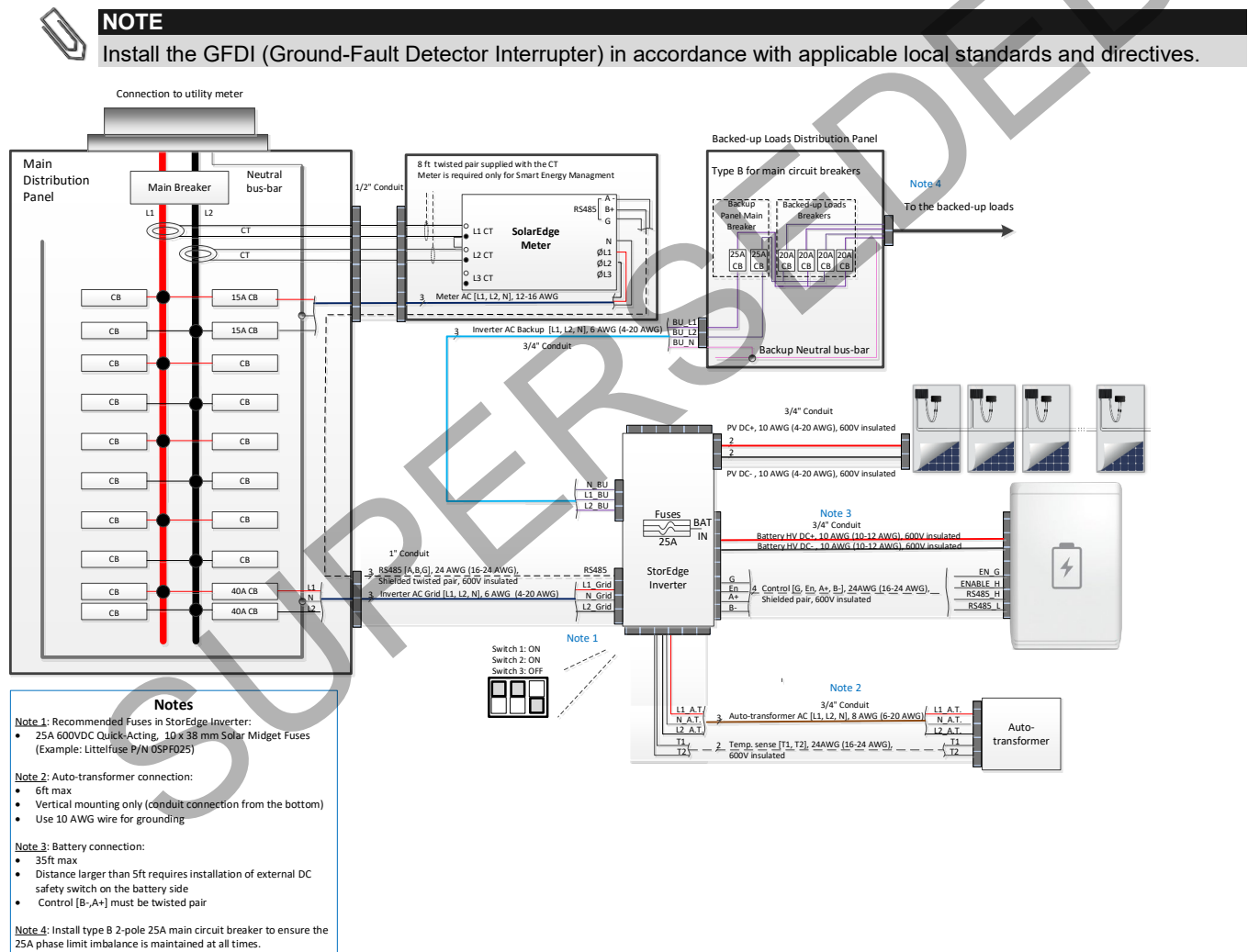

Figure 4: Smart Energy Management with Backup Power - Basic Configuration

The following diagram shows the RS485 termination switch location on the inverter communication board (SW7) and on the RS485 Plug-in (RS485 module).

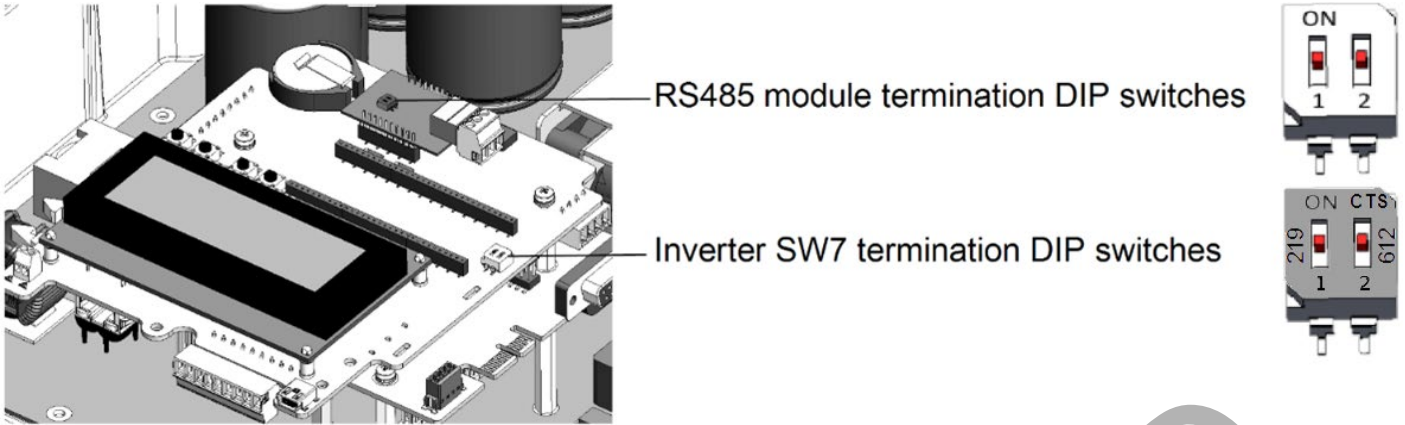

Figure 5: RS485 termination switch location

Set the **SW7** DIP switches as follows:

- Left switch (RS485-1 port): ON (up) = terminated, OFF (down) = non terminated
- Right switch (RS485-2 port, if installed): ON (up) = terminated, OFF (down) = non terminated

The following diagram illustrates the connection of the system components when using two batteries. In this case, an external combiner box is needed. For enlarged segments of this diagram refer to *Appendix E – Detailed System Connection Drawings*.

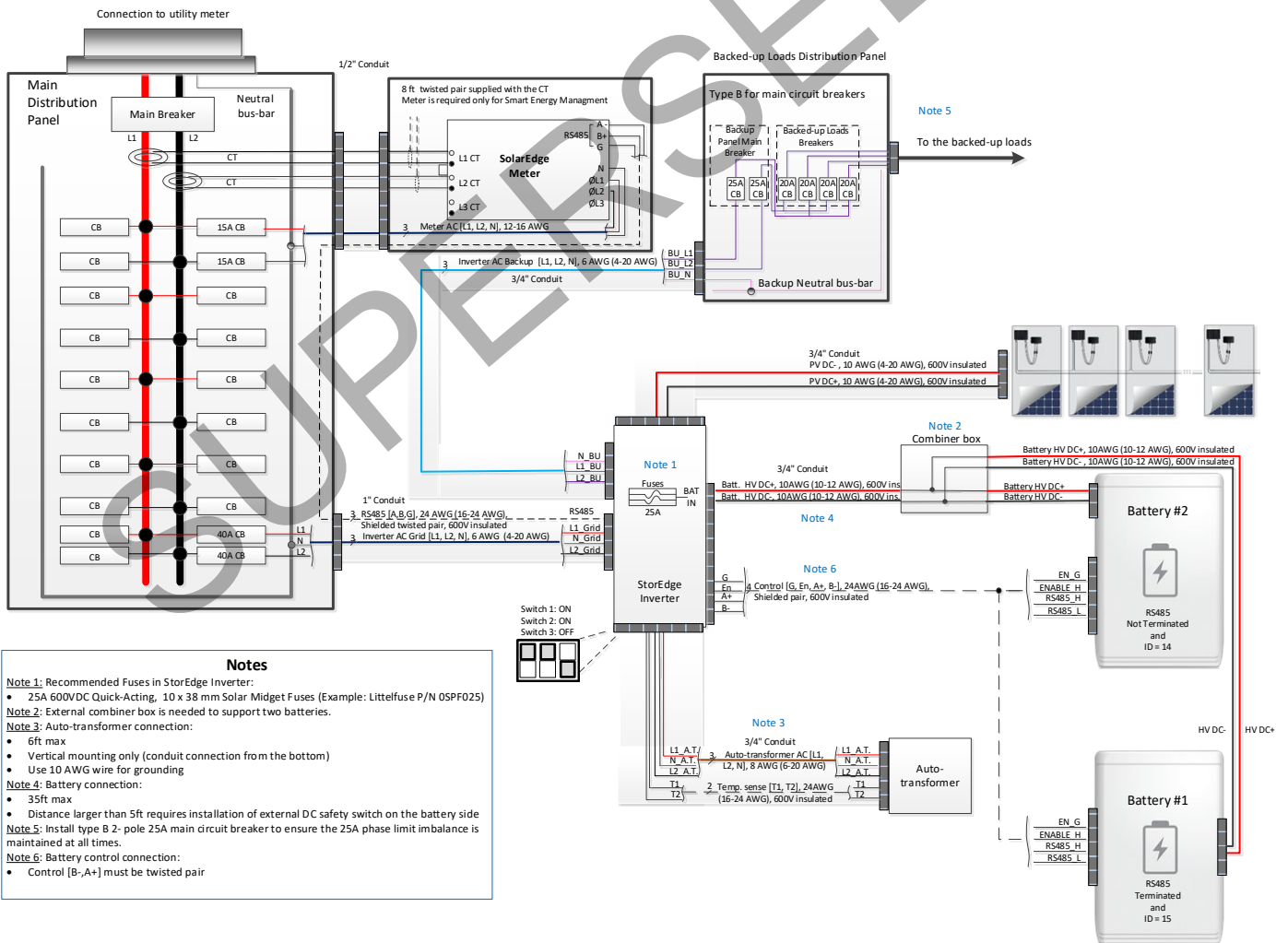

Figure 6: Smart Energy Management with Backup Power Using Two Batteries

The following diagram illustrates the connection of the system components when using two inverters and two batteries. In this case, an RS485 daisy-chain connects the meter to the first inverter, and connects the first inverter to the second inverter. For enlarged segments of this diagram, refer to *Appendix E – Detailed System Connection Drawings*.

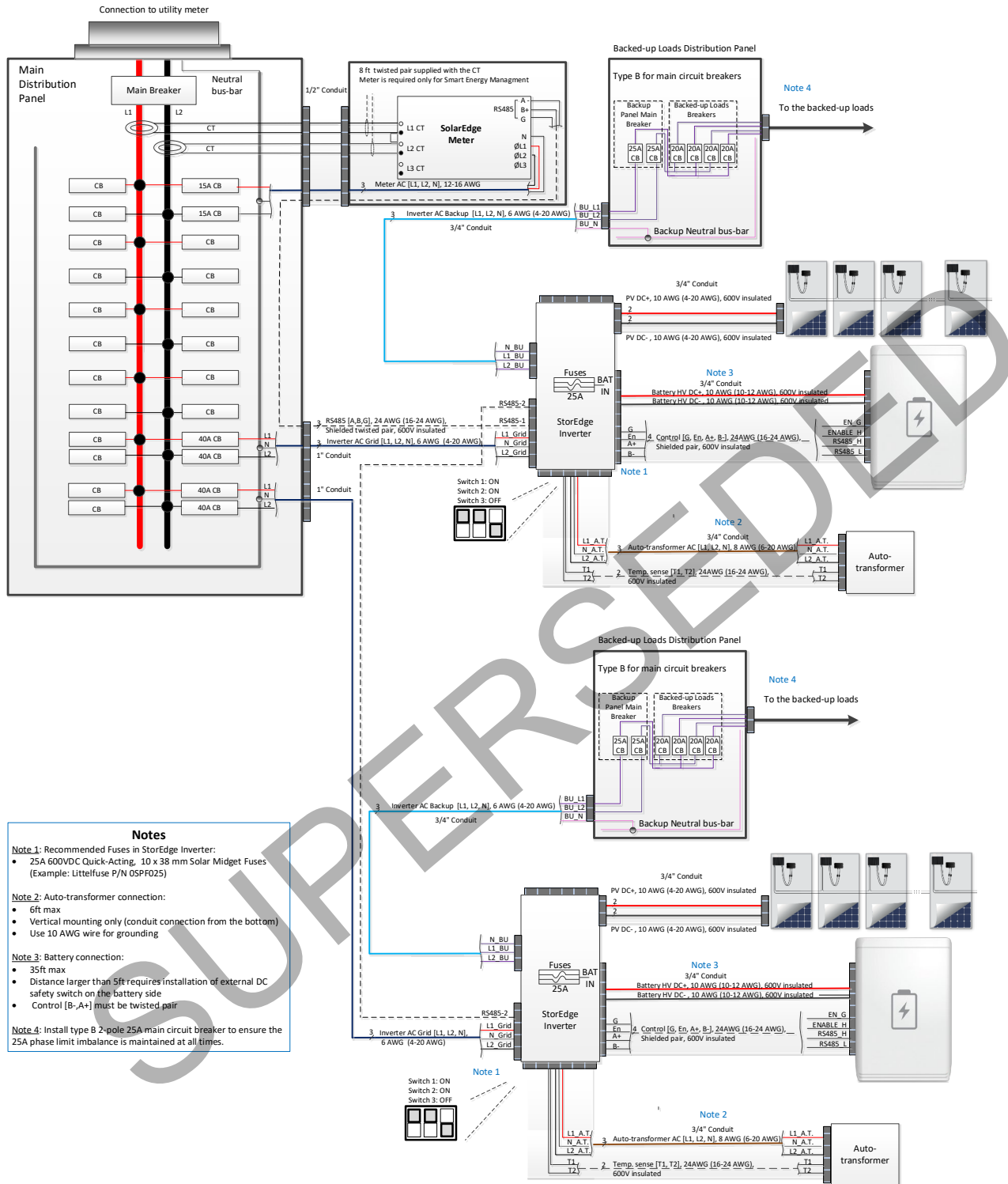

Figure 7: Smart Energy Management with Backup Power Using Two Inverters and Two Batteries

Basic Configuration

This configuration is based on one of each of the StorEdge components and is suitable for most residential systems.

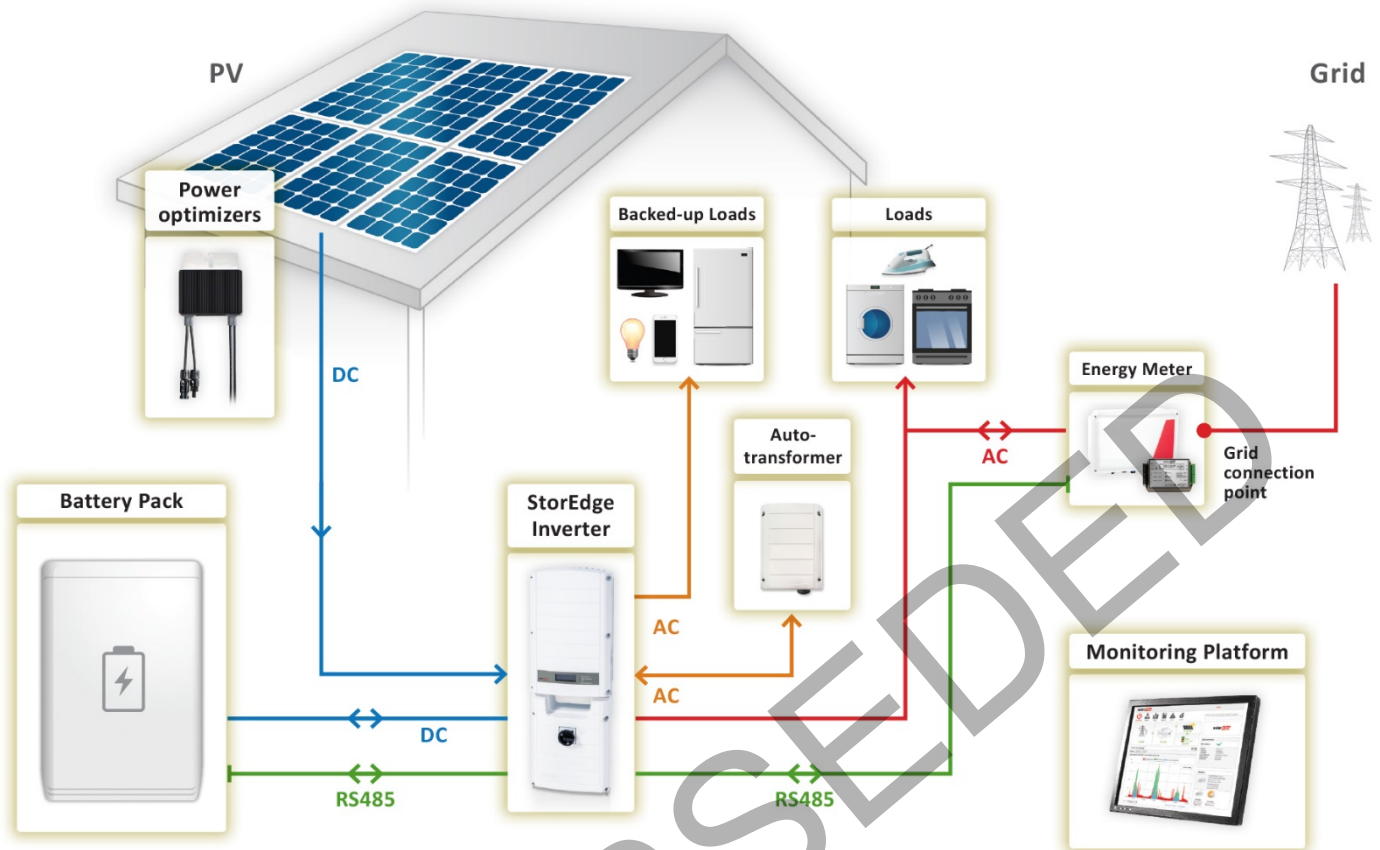

Figure 8: Smart Energy Management with Backup Power - Basic Configuration

► **To Connect and Configure the Meter and the Battery:**

- 1 Make sure the wiring is connected as specified in the diagram above. For detailed instructions, see the *StorEdge Inverter Wiring Guide & On Site Checklist*: https://www.solaredge.com/sites/default/files/storedge_wiring_quick_guide_and_on_site_checklist_na.pdf
- 2 Depending on your battery model, turn on the battery’s auxiliary power switch or the disconnect switch. For details, see *Appendix F - Powering the LG Chem Battery off and on* on 53.
- 3 Turn the battery Circuit Breakers ON.
- 4 Turn the AC Breaker of the inverter ON.
- 5 If a firmware upgrade is required, see the *StorEdge Inverter Wiring Guide & On Site Checklist*: https://www.solaredge.com/sites/default/files/storedge_wiring_quick_guide_and_on_site_checklist_na.pdf
- 6 Check the Communication status screen and verify that the battery and the meter are properly connected and configured:
 - **Dev** – The type of device configured for connection to the port.
 - **Prot** – the number of devices configured to communicate with the inverter on the RS485-1 bus.
 - **##** – the number of devices that communicate with the inverter on the RS485-1 bus.

```

Dev Prot ##
RS485-1 <MLT> <02> <02>
ZigBee <---> <---> <--->
```

- 7 If **Dev** is not “MLT”, the system is not pre-configured and requires full configuration. Proceed with step 9 below.
 - Verify that the number under **Prot** displays the number of configured devices. If not, proceed with step 9 below.
 - Verify that the number under **##** displays the number of communicating devices. If not, proceed with step 9 below.

- 8 Check that the meter CT rating is set to the correct value as appears on the CT label in order to complete the meter setting. To check, select **Communication** → **RS485-1 Conf** → **Device type** → **Multi Devices** → **Meter 2** → **Device Type** → **Revenue Meter**. The meter configuration screen is displayed. Configure the meter:
 - a. Check that the CT value is set as it appears on the CT label. If it is not configured correctly, check the communication as described in section below: *To verify communication*.
 - b. If communication is verified, skip steps 9 to 11 and proceed with the backup power setup as described below.
- 9 Select **Communication** → **RS485-1 Conf** → **Device Type** → **Multi-devices**. A list of devices is displayed.
- 10 Select **Meter 2**. The meter configuration screen is displayed. Configure the meter:
 - a. Select **Device Type** → **Revenue Meter**
 - b. Check that the CT value is set as it appears on the CT label. To check, select **CT Rating** → **<xxxxA>**. If it is not configured correctly, use the up/down arrows to set each character, press <Enter> to set the character and move to the next one, then long press on <Enter> to set the value.
 - c. Select **Meter Func.** and select the function according to the meter CT(s) location:
 - i. **Export + Import**: meter CT(s) at grid connection point (as shown in the diagram above)
 - ii. **Consumption**: meter CT(s) at load consumption point
- 11 Select **Battery 1**. The battery configuration screen is displayed. Configure the battery:
 - a. Select **Device Type** → **Battery Pack**
 - b. Select the battery protocol: **LG Battery**, and **ID: 15**



NOTE

When using a revenue grade StorEdge inverter:

- The built-in meter is pre-configured as **Meter 1** and as a **Production** meter.
- The **Prot** and **##** in the Communication status screen will increase by 1. For example, if there is an internal meter, an external meter and a battery, the screen should display Prot=03 and ##=03.

► **To Set Up Backup Power:**

- 1 To **Enable** backup capability:
 - Enter Setup mode to display the main menu:

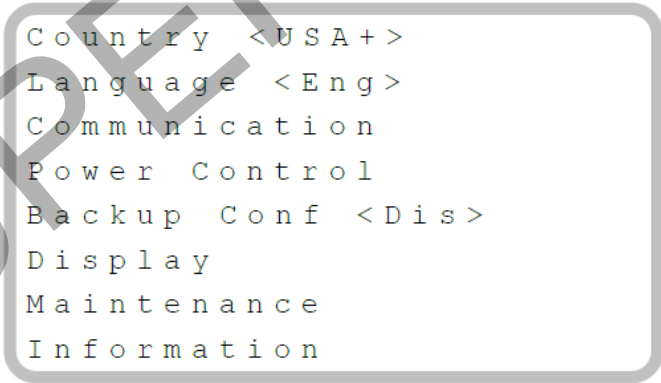

- From the main menu, select **Backup Conf**.
 - Select **Backup** and set it to **Enable**.
- 2 To set a minimum battery charge level, so that the battery will always have energy stored in case backup power is needed, perform the following steps:
 - Select **Power Control** → **Energy Manager** → **Storage Control**. The following is displayed:

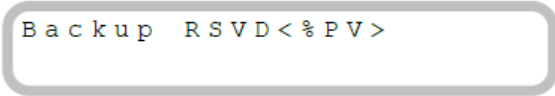

- Select **Backup RSVD** and set the required level as percentage of the battery capacity. Set **%PV** according to user requirement.
- 3 After configuring the meter, the battery and backup power, proceed with Smart Energy Management application configuration for maximize self-consumption or for charge/discharge profile programming.

► **To Set Up Maximize Self-consumption:**

- 1 Select **Power Control** → **Energy Manager** → **Energy Ctrl** → **Max Self-Consume**.

► **To Set Up Charge/Discharge Profile Programming:**

- 1 Select **Power Control** → **Energy Manager** → **Energy Ctrl** → **Time of Use**.
- 2 Select **Storage Ctrl** → **AC Charge Lim** → **Limit Type**, and set one of the following limits:
 - a. Set %PV to enter a limit as a percentage of year-to-date energy production.
 - b. Set kWh to enter a fixed annual energy limit.
 - c. Set None to unlimit the charging.
- 3 Profile loading can be done remotely from the monitoring platform. *Appendix A – Creating a Charge/Discharge Profile* for information on creating a charge/discharge profile.
 - a. In the monitoring platform, click the Admin icon and select the Energy Manager tab.
 - b. Select **Set profile from server** check box.
 - c. Select **Apply this profile** and select the profile name from the drop-down list. The profile is applied to all inverters in the site.
 - d. Click **Save**. The Energy Manager window displays:
 - i. In the Storage mode column: "Storage Profile" (if you applied a profile)
 - ii. In the Storage profile name column: The specific profile that was applied to the site, as reported by each inverter.

► **To verify communication:**

After connecting and configuring a communication option, perform the following steps to check that the connection to the monitoring server has been successfully established.

- 1 Turn on the AC to the inverter by turning ON the circuit breaker on the main distribution panel.
- 2 Wait for the inverter to connect to the SolarEdge monitoring portal. This may take up to two minutes.
- 3 Push the OK / LCD button several times, until you see the communication screen on the LCD panel:

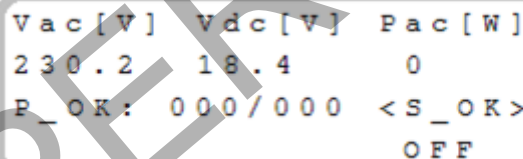

```

Vac [V]  Vdc [V]  Pac [W]
230.2   18.4     0
P_OK: 000/000  <S_OK>
                OFF
  
```

S_OK: Indicates that the connection to the SolarEdge monitoring platform is successful.

- 4 For additional verification, refer to *Appendix B – Verifying StorEdge Functionality*.

► **To test the battery:**

The test is available in CPU version 3.24xx and higher (but not in version 4.x.xxx).

If two batteries are installed, the active battery will be tested first, and then the standby battery. If the active battery fails the test, the test will stop and the standby battery will not be tested.

1. Verify that AC is ON.
2. Turn the inverter ON/OFF switch to ON.
3. Make sure the Connection Unit is ON.
4. Enter Setup mode and select **Maintenance** → **StorEdge Self-Test** → **Start Test**. The battery charges and discharges within approximately two minutes to check performance.

During the test, the following message is displayed:

Short test in
progress...

Any button to stop

Upon the test completion, the following message is displayed:

Self-test completed
successfully

Any button to cont.

If an error message is displayed during the test, use the following table to resolve the error.

Error	Solution
Bat 1 charge failed	Check that the power and communication cables between the battery and inverter are properly connected.
Bat 1 discharge failed	Check that the power and communication cables between the battery and inverter are properly connected.
Low SOE	Charge the battery to 20 percent SOE at least.
Battery comm. error	Check that the communication cables between the battery and inverter are properly connected.
Turn switch to On	Turn the inverter ON/OFF switch to ON.

Large Residential PV Systems

For residential sites with large PV systems, a StorEdge inverter and a SolarEdge single phase inverter may be installed together. The StorEdge inverter manages the battery and functions as a PV inverter, and the second inverter is used for production of the additional PV power. During power outages, the StorEdge inverter provides power to backed-up loads, and the second inverter remains shut down until the grid is back.

If the inverter connected to the battery has only a single RS485 bus, installation of an RS485 Plug-in is required. Refer to the RS485 Plug-in Installation Guide at: http://www.solaredge.com/files/pdfs/RS485_expansion_kit_installation_guide.pdf. For instructions on how to check if the inverter has a single RS485 bus or two, refer to *Appendix D – Check Number of RS485 Buses*.

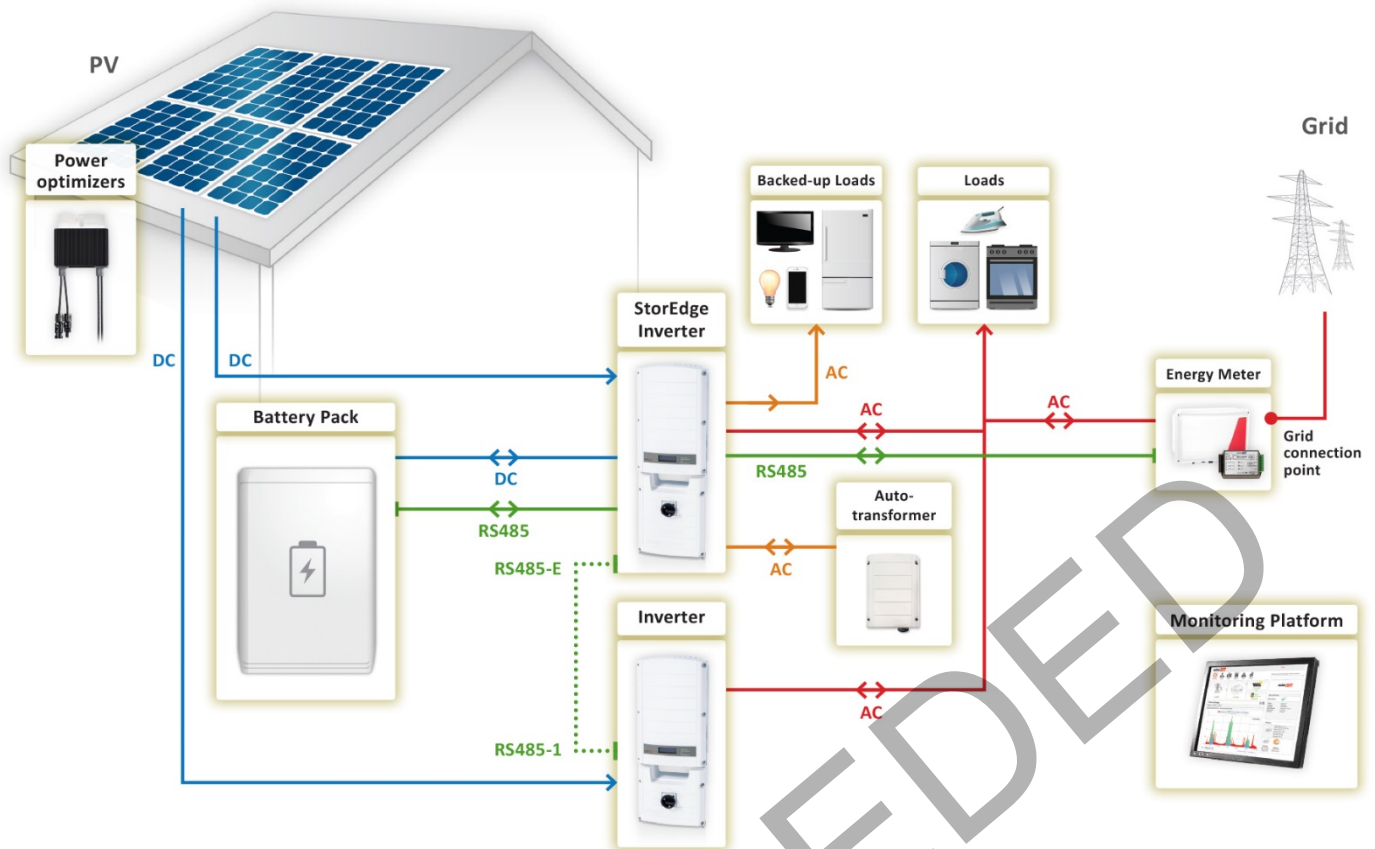

Figure 9: Smart Energy Management with Backup Power - Large Residential PV Systems

► **To Configure the System:**

- 1 Configure the meter, battery and backup power of the StorEdge inverter as described in the section *Basic Configuration* on page 9.
- 2 Configure the second inverter as described in <https://www.solaredge.com/sites/default/files/se-single-and-three-phase-inverter-user-manual-na.pdf>.
- 3 The same CPU version is required for both inverters.

► **To Set Up Smart Energy Management:**

- After configuring the meter, battery and backup power, proceed with maximizing self-consumption or charge/discharge profile programming as described in the *Basic Configuration* on page 10.

► **To Configure Inverters Communication:**

- 1 If needed, install the RS485 Plug-in in the StorEdge inverter. If there is an RS485-2 port in the inverter, use it instead of the expansion kit. *The RS485-E port in the following instructions refers either to the Expansion port or to the RS485-2 port.*
- 2 Connect the StorEdge inverter RS485-E port to the second inverter’s RS485-1 port using an RS485 twisted pair cable. Terminate both sides. From the StorEdge inverter:
 - a. Select **Communication** → **RS485-E Conf** → **Enable**. Press Enter to continue.
 - b. Select **Protocol** → **Master**.
 - c. Select **Slave Detect**. Verify that the inverter reports the correct number of secondary inverters.



NOTE

The second inverter does not require communication configuration.

► **To Verify Communication:**

- Verify communication as described in *Basic Configuration* on page 11.

► **To test the battery:**

- Test the battery as described in *Basic Configuration* on page 11.

Additional Capacity with Two Batteries

For sites where additional battery capacity is needed (for example, to enable backed-up loads to be powered from the battery for longer periods), two batteries may be connected to a single StorEdge inverter.

In this configuration, only one battery operates at any given time – i.e. the two batteries provide additional capacity only, not additional power.

For these installations, the two batteries must have a different part number and ID; both inverters require CPU version 3.2305 and above. If an upgrade is needed, refer to the StorEdge and Smart Energy Firmware Updates page at:

<https://www.solaredge.com/us/storedge/firmware>.

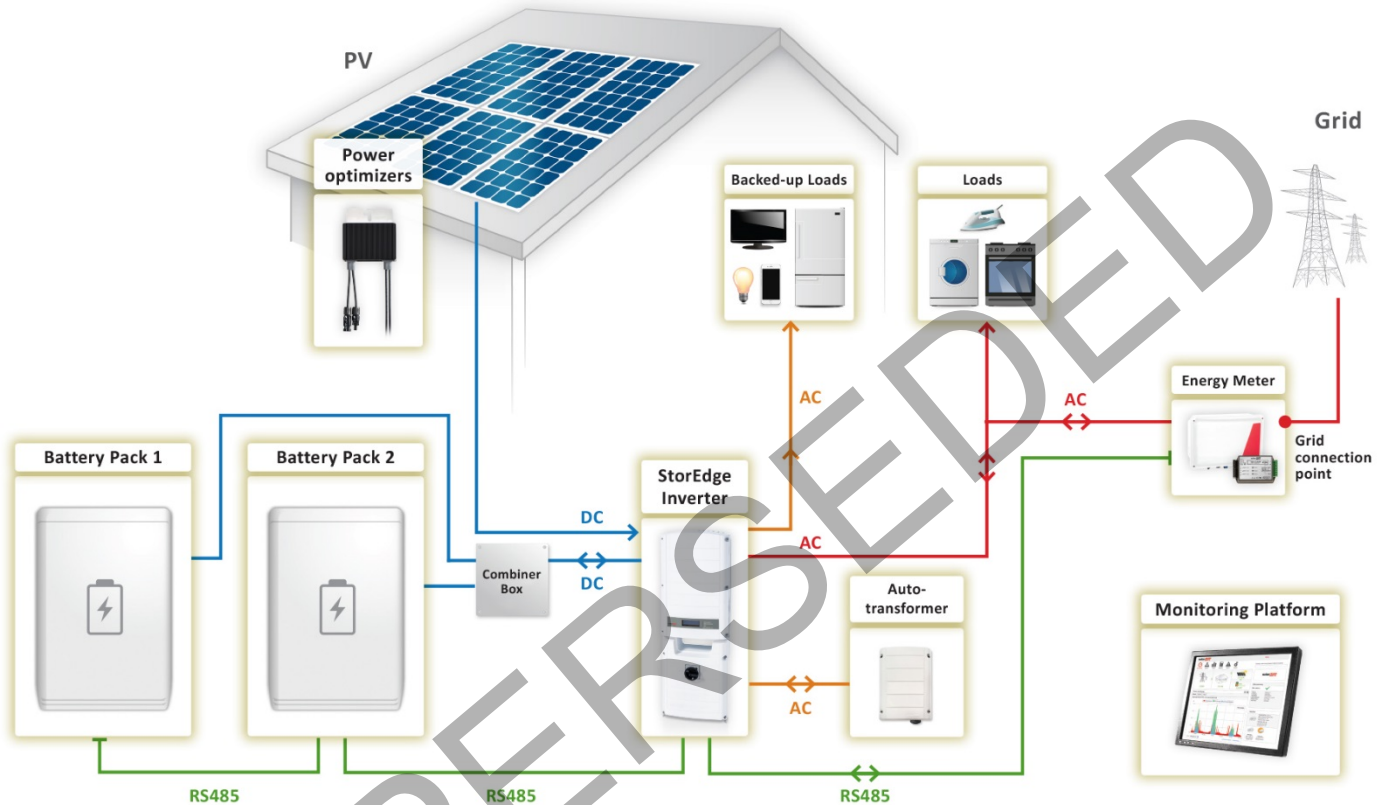

Figure 10: Smart Energy Management with Backup Power - Additional capacity with two batteries

► To Configure the System:

- 1 Configure the meter, Battery 1 and backup power as described in the *Basic Configuration* on page 9.
- 2 Configure Battery 2:
 - a. Select **Communication** → **RS485-1 Conf** → **Device Type** → **Multi-devices**. A list of devices is displayed.
 - b. Select Battery 2. The battery configuration screen is displayed.
 - c. Select **Device Type** → **Battery Pack**. Battery 2 is pre-configured to LG with device ID 14.

► To Set Up Smart Energy Management:

- After configuring the meter, battery and backup power, proceed with maximizing self-consumption or charge/discharge profile programming as described in the *Basic Configuration* on page 10. Repeat this configuration for each of the inverters.

► Verifying Communication:

- Verify communication as described in in the section *Basic Configuration* on page 11.

► To test the battery:

- Test the battery as described in in the section *Basic Configuration* on page 11.

Additional Capacity and Power with Multiple Inverters

For sites where additional capacity and power with multiple inverters is needed (for example, to enable more backed-up loads to be powered simultaneously), two StorEdge inverters and two batteries may be installed. Each battery connects through a separate StorEdge Inverter, and each inverter manages the battery and the PV connected to it. Backed-up loads are connected to each inverter through separate load panels and auto-transformers. The inverter connected to the meter operates as the system manager.

For these installations, both inverters require CPU version 3.2305 and above. If an upgrade is needed, refer to the StorEdge and Smart Energy Firmware Updates page at: <https://www.solaredge.com/us/storedge/firmware>.

If the inverter connected to the battery only has a single RS485 bus, installation of an RS485 Plug-in is required. Refer to the RS485 Plug-in Installation Guide at: http://www.solaredge.com/files/pdfs/RS485_expansion_kit_installation_guide.pdf. For instructions on how to check if the inverter has a single RS485 bus or two, refer to *Appendix D – Check Number of RS485 Buses*.

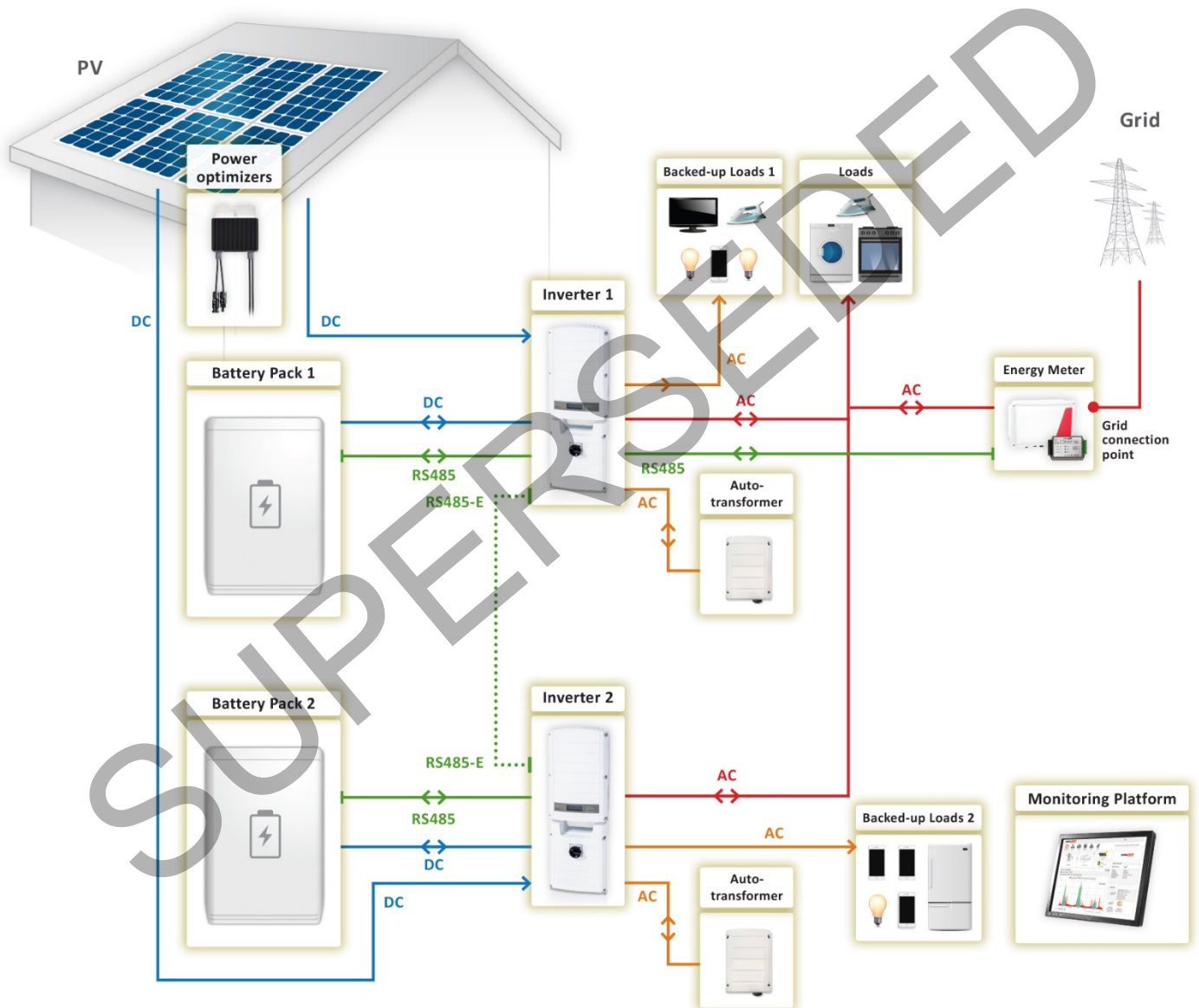

Figure 11: Smart Energy Management with Backup Power - Additional capacity and power with multiple inverters

► To Configure RS485 Communication:

- 1 If needed, install the RS485 Plug-in in the StorEdge inverter. If there is an RS485-2 port in the inverter, use it instead of the expansion kit. *The RS485-E port in the following instructions refers either to the Expansion port or to the RS485-2 port.*
- 2 Connect the inverter 1 RS485-E port to the inverter 2 RS485-E port using an RS485 twisted pair cable. Make sure to terminate both sides.
- 3 Configure the inverter 2 RS485-E port: Select **Communication** → **RS485-E Conf** → **Enable**.

- 4 Configure the inverter 1 RS485-E port:
 - a. Select **Communication** → **RS485-E Conf** → **Enable**. Press Enter to continue.
 - b. Select Protocol → Master
 - c. Select **Slave Detect** on inverter 1. Verify that the inverter reports the correct number of secondary inverters.

▶ **To Configure the System:**

- 1 Configure the meter, battery and backup power of inverter 1 as described in the *Basic Configuration* on page 9.
- 2 Configure the battery and backup power of inverter 2 as described in the *Basic Configuration* on page 9.
- 3 Make sure that the meter is not configured on inverter 2:
 - a. Select **Communication** → **RS485-1 Conf** → **Device Type** → **Multi-devices**.
 - b. Select **Meter2** → **Meter Type** → **None**.

▶ **To Set Up Smart Energy Management:**

- After configuring the meter, battery and backup power, proceed with maximizing self-consumption or charge/discharge profile programming as described in the *Basic Configuration* on page 9. Repeat this configuration for each of the inverters.

▶ **To Verify Communication:**

- Verify communication of both inverters as described in the *Basic Configuration* on page 8.

▶ **To test the battery:**

- Test the battery as described in *Basic Configuration* on page 11.

AC Coupling using a non-SolarEdge Inverter

For sites with an already installed PV system with a non-SolarEdge inverter, the StorEdge inverter can be AC-coupled to the existing inverter, i.e. the StorEdge inverter used to manage the battery is connected to the AC output of the existing inverter and charges the battery using the PV power produced by the non-SolarEdge inverter.



NOTE

The meter is used for Smart Energy Management and does not measure the non-SolarEdge inverter production. The production and self-consumption information in the monitoring portal does not take into account this production.

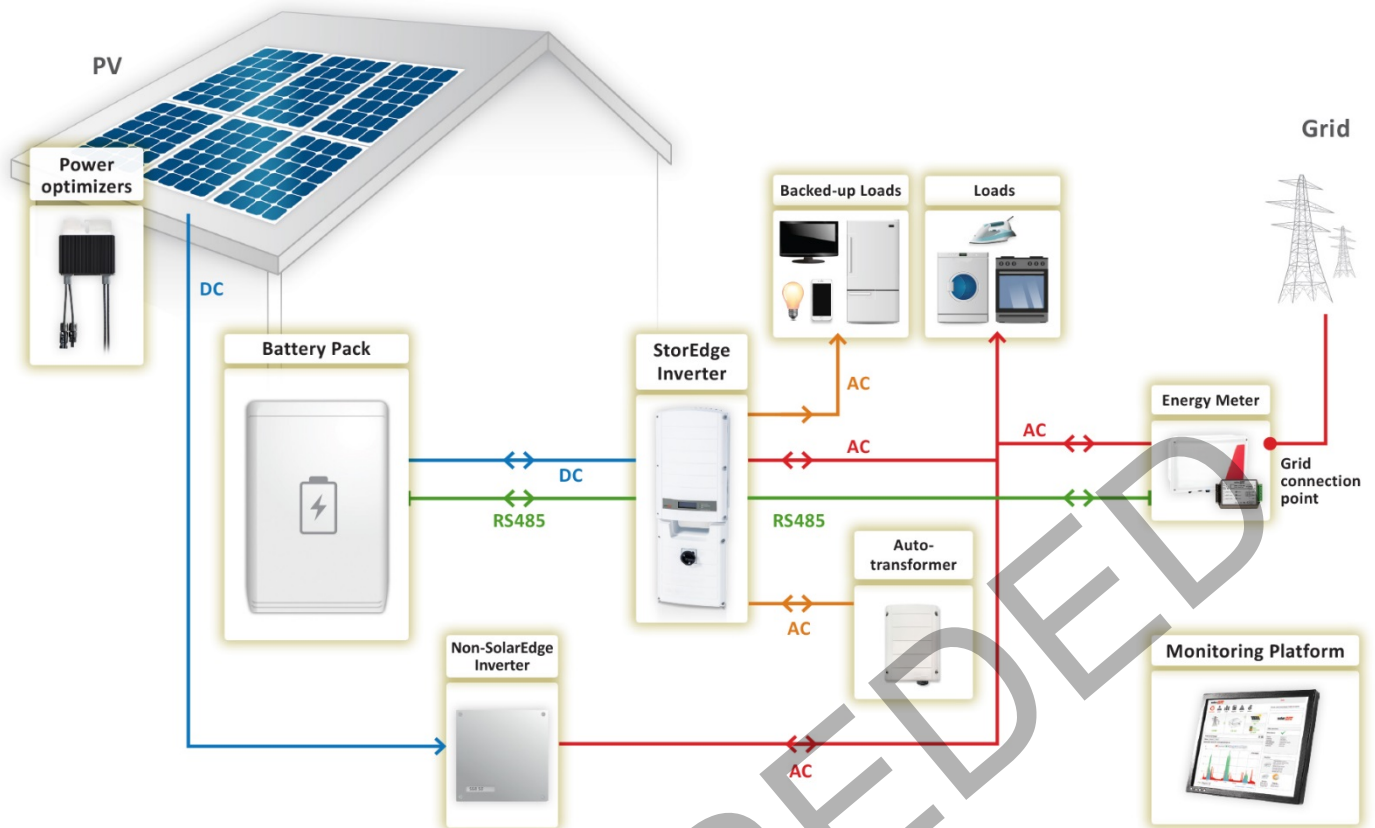

Figure 12: Smart Energy Management with Backup Power - AC Coupling using a non-SolarEdge Inverter

► **To Configure the Meter and the Battery:**

- Configure the meter, battery and backup power as described in the section *Basic Configuration* on page 9.

► **To Set Up Smart Energy Management:**

- After configuring the meter, battery and backup power, proceed with maximizing self-consumption as described in the section *Basic Configuration* on page 10.

► **To Verify Communication:**

- Verify communication as described in the section *Basic Configuration* on page 11.

► **To test the battery:**

- Test the battery as described in *Basic Configuration* on page 11.

Backup Power Only - System Configurations

In this mode, stored energy is used for backup power only. In case of a power outage, the inverter automatically switches to backup mode, disconnecting from the grid and supplying power to backed-up loads.

A backup power only system can be upgraded to support Smart Energy Management applications by installing a SolarEdge Energy Meter and reconfiguring the system as described in the chapter *Smart Energy Management with Backup Power* on page 2.

Configuration is performed as described in the *Smart Energy Management with Backup Power* chapter, **without setting up smart energy management**.

System Connection

The following diagram illustrates the connection of the system components when using the basic configuration for backup power only: one StorEdge inverter, one auto-transformer and one battery. For enlarged segments of this diagram, refer to *Appendix E – Detailed System Connection Drawings*.

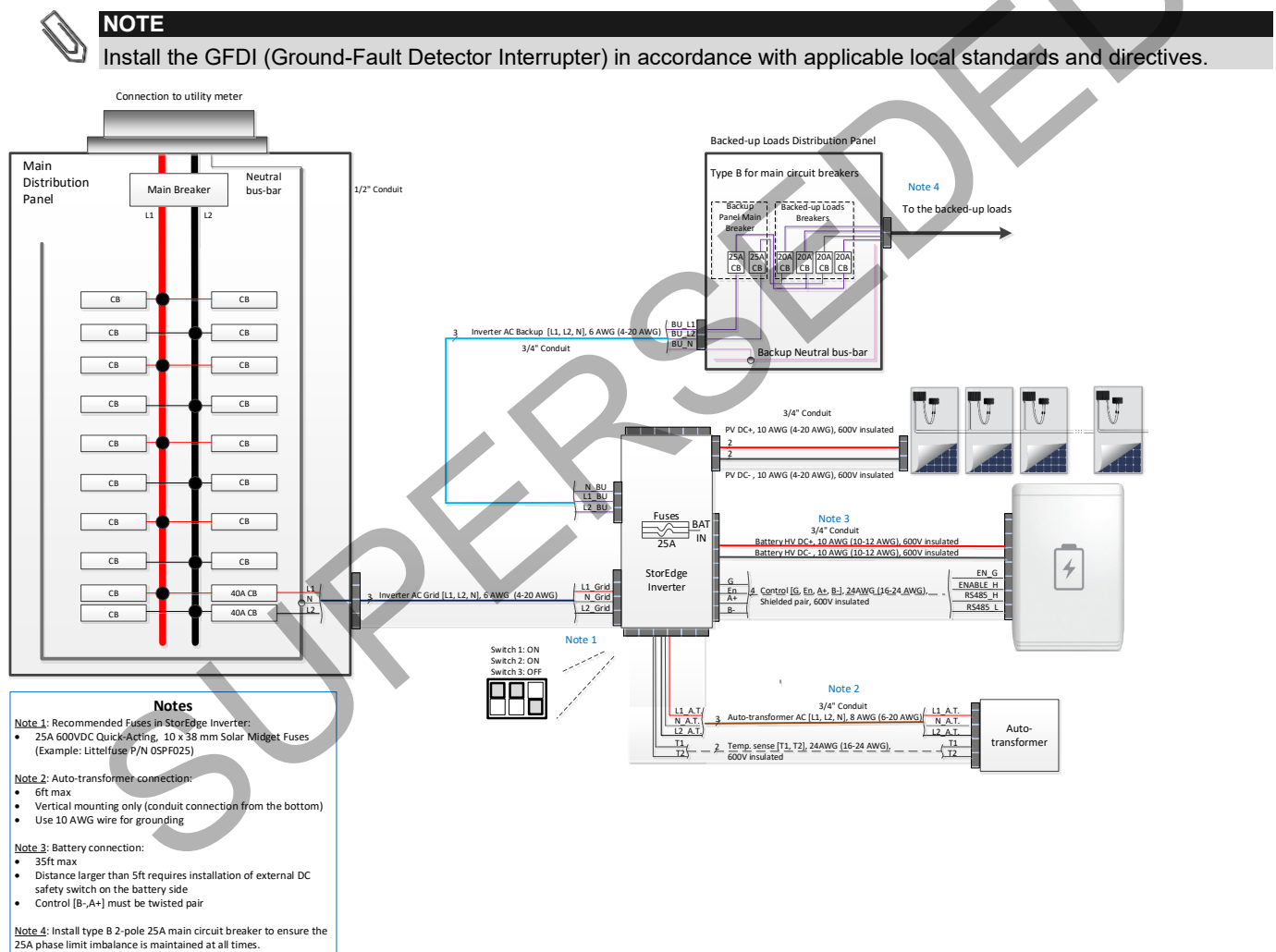

Figure 13: Backup Power Only - Basic Configuration

The following diagram illustrates the connection of the system components when using two batteries. In this case, an external combiner box is needed. For enlarged segments of this diagram refer to *Appendix E – Detailed System Connection Drawings*.

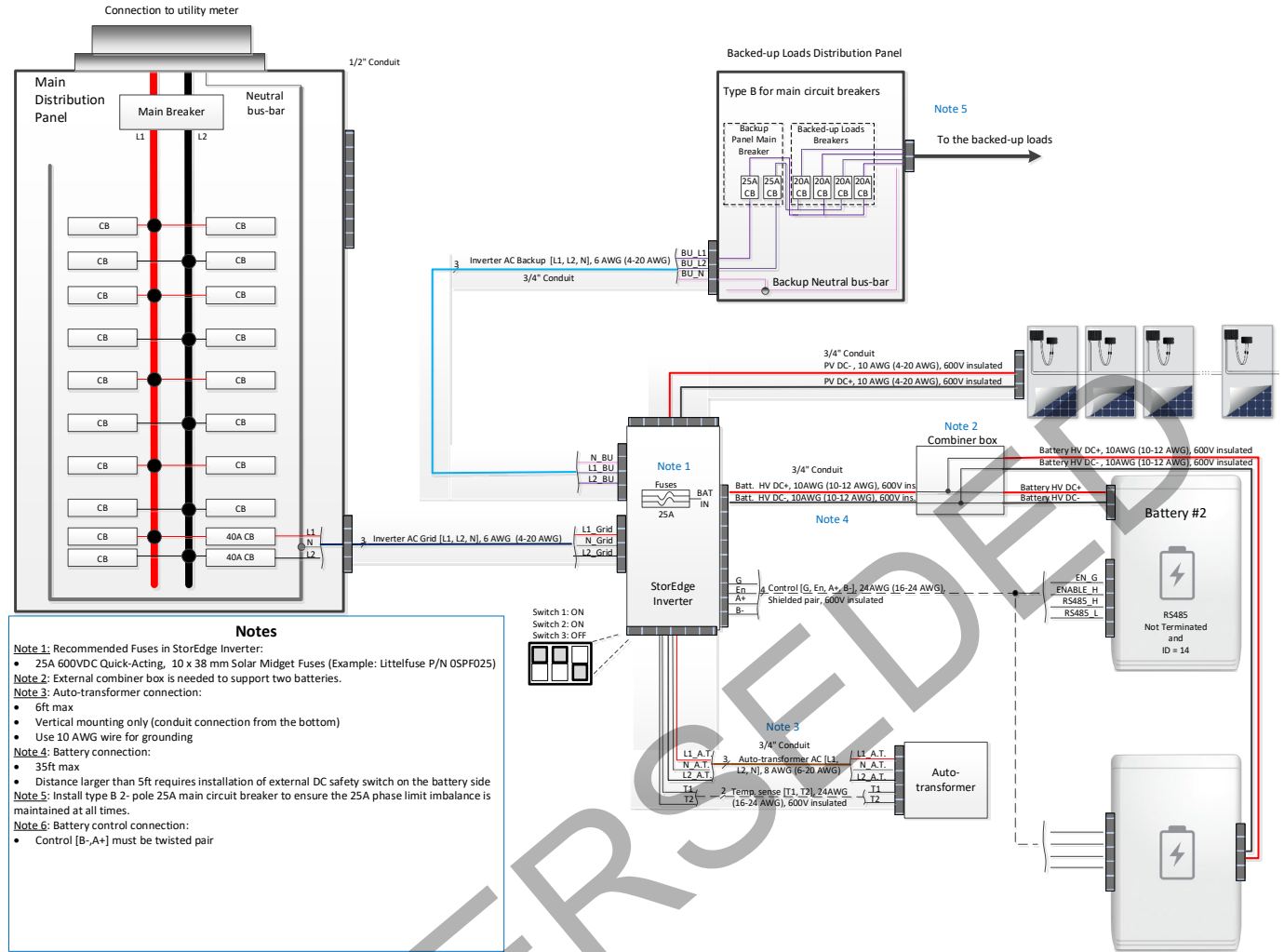

Figure 14: Backup Power Only Using Two Batteries

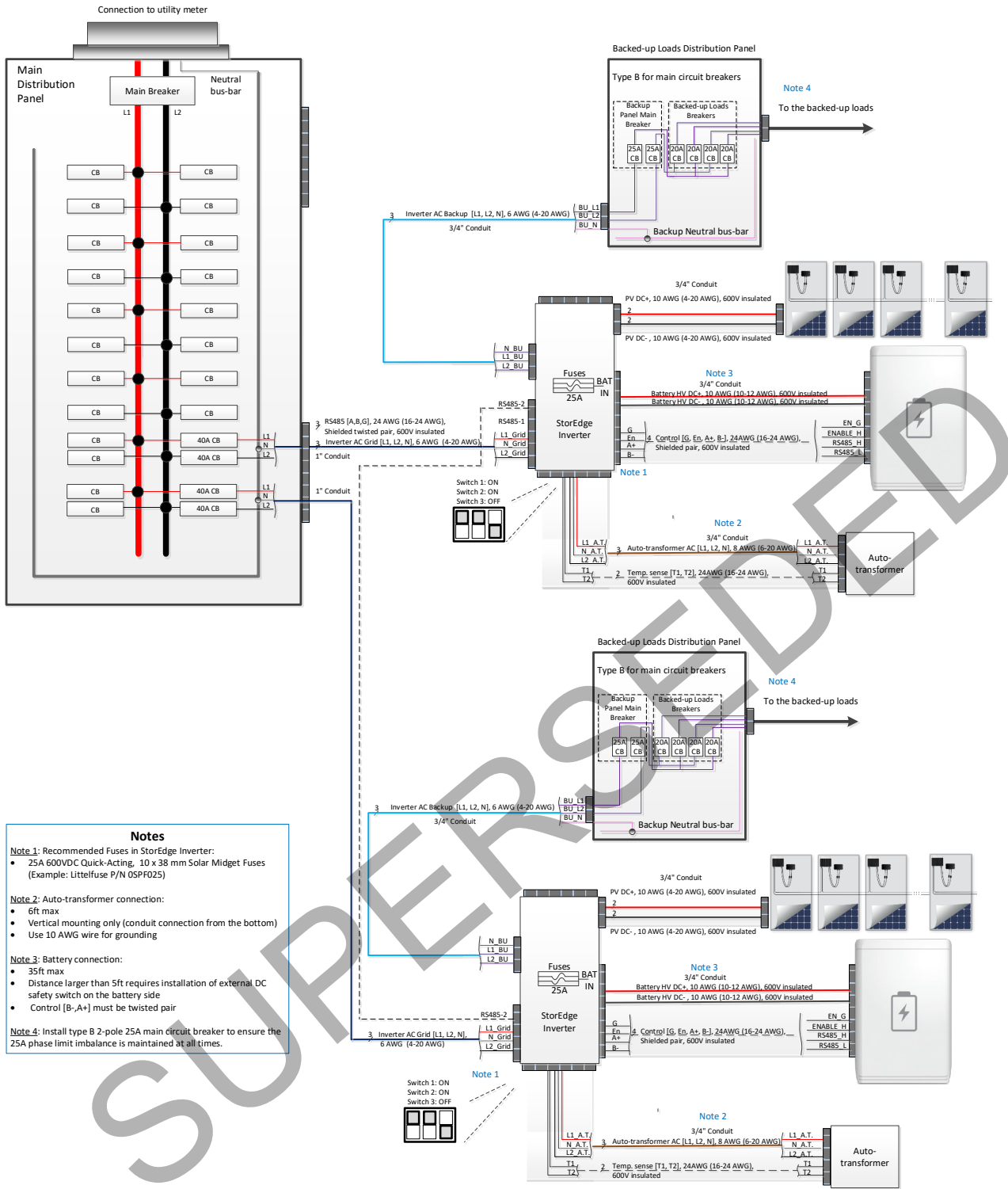

Figure 15: Backup Power Only Using Two Inverters and Two Batteries

Basic Configuration

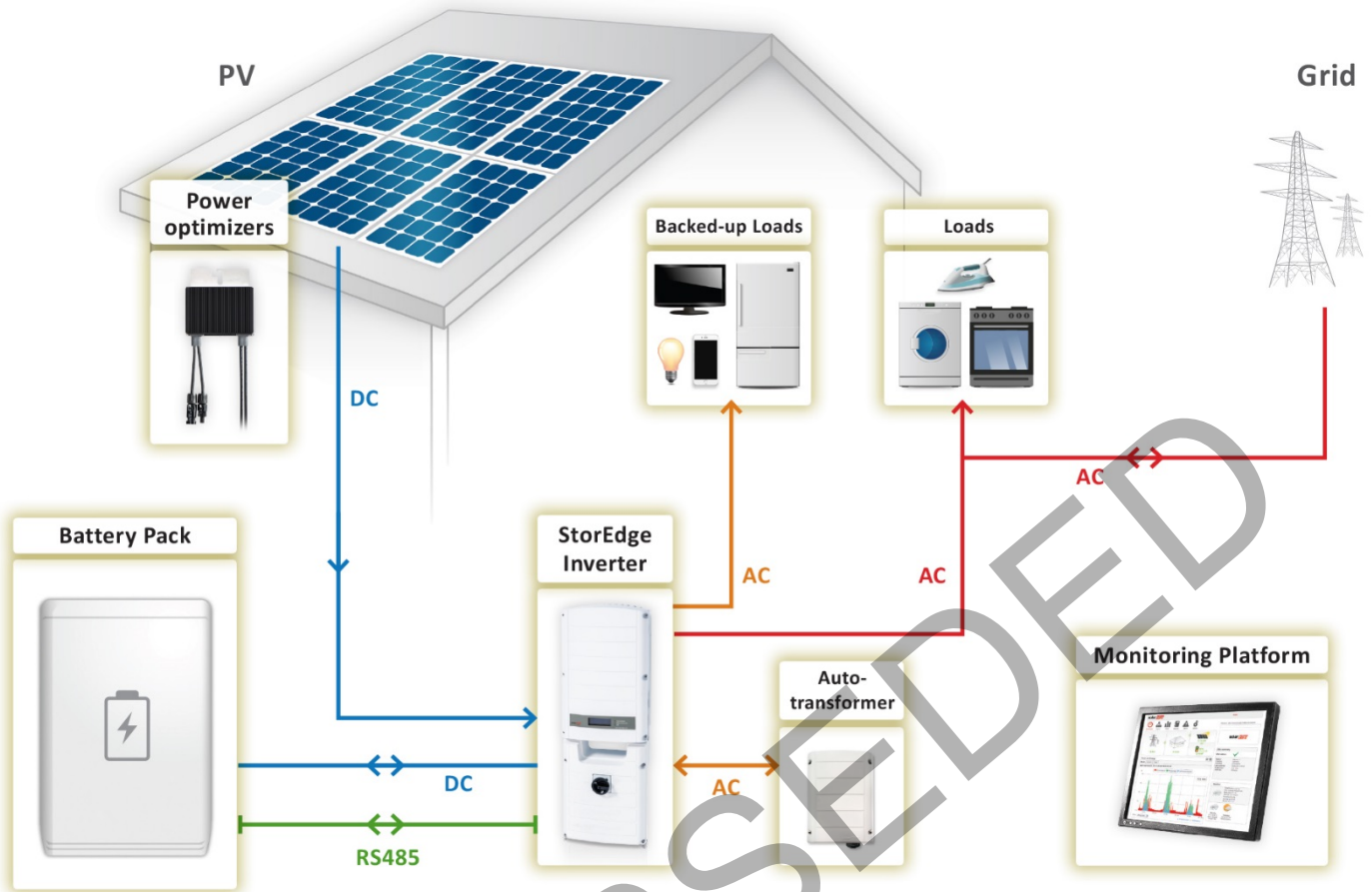

Figure 16: Backup Power Only – Basic Configuration

The following procedure is intended for **backup power only** configurations. For all other procedures, follow the steps provided in the *Basic Configuration* section of the chapter *Smart Energy Management with Backup Power*.

► **To Configure the System:**

- 1 Make sure the wiring is connected according to the diagram above.
- 2 Configure Meter 2 to None:
 - a. Select **Communication** → **RS485-1 Conf** → **Device Type** → **Multi-devices**.
 - b. Select **Meter2** → **Meter Type** → **None**.
- 3 Check the Communication status screen and verify that the battery is properly connected and configured:

```

Dev Prot ##
RS485-1<MLT> <01> <01>
ZigBee <---><---><--->
    
```

- If Dev is not **MLT**, the system is not pre-configured and requires full configuration. Proceed with step 4 below.
 - If **## ≠ 01** or **Prot ≠ 01**, the battery and/or meter are not configured or communicating correctly. Check the configuration. Check the wiring connection. Proceed with step 4 below.
 - If **## = 01** and **Prot = 01** – the battery is configured and communicating properly. Skip steps 4 to 3b below and proceed with set up backup power only as described below.
- 4 Select **Communication** → **RS485-1 Conf** → **Device Type** → **Multi-devices**. A list of devices is displayed.

5 Configure Battery 1:

- a. Select **Battery 1**. The battery configuration screen is displayed.
- b. Configure the battery: **Device Type** → **Battery Pack**



NOTE

When using a revenue grade StorEdge inverter:

- The built-in meter is pre-configured as **Meter 1** and as a **Production** meter.
- The **Prot** and **##** in the Communication status screen will increase by 1. For example, if there is an internal meter, an external meter and a battery, the screen should display Prot=03 and ##=03.

► **To Set Up Backup Power Only:**

- 1** Enter Setup mode to display the main menu.
- 2** From the main menu, select **Power Control**. A menu similar to the following is displayed:

```
Grid Control <En>
Energy Manager
RRCR Conf.
Reactive Pwr Conf.
Active Pwr Conf.
Phase Balance <Dis>
Wakeup Conf.
P ( f )
Advanced
Load Defaults
```

- 3** Select **Energy Manager**. The following screen is displayed:

```
Limit Control <Dis>
Energy Ctrl <Dis>
Storage Control
```

- 4** Select **Energy Ctrl**
- 5** Select Backup only. The Energy Manager screen changes to display the following:

```
Limit Control <Dis>
Energy Ctrl <BU>
Storage Control
```

► **To Verify Communication:**

After connecting and configuring a communication option, perform the following steps to check that the connection to the monitoring server has been successfully established.

- 1** Turn on the AC to the inverter by turning ON the circuit breaker on the main distribution panel.
- 2** Wait for the inverter to connect to the SolarEdge monitoring portal. This may take up to two minutes.
- 3** Push the OK / LCD button several times, until you see the communication screen on the LCD panel:

```
Vac [V] Vdc [V] Pac [W]
230.2 18.4 0
P_OK: 000/000 <S_OK>
OFF
```

S_OK: Indicates that the connection to the SolarEdge monitoring platform is successful.

- 4** For additional verification, refer to *Appendix B – Verifying StorEdge Functionality*.

► **To test the battery:**

The test is available in CPU version 3.24xx and higher (but not in version 4.x.xxx).

If two batteries are installed, the active battery will be tested first, and then the standby battery. If the active battery fails the test, the test will stop and the standby battery will not be tested.

- 1 Verify that AC is ON.
- 2 Turn the inverter ON/OFF switch to ON.
- 3 Make sure the Connection Unit is ON.
- 4 Enter Setup mode and select **Maintenance** → **StorEdge Self-Test** → **Start Test**. The battery charges and discharges within approximately two minutes to check performance. During the test, the following message is displayed:

During the test, the following message is displayed:

```
Short test in
progress...

Any button to stop
```

Upon the test completion, the following message is displayed:

```
Self-test completed
successfully

Any button to cont.
```

If an error message is displayed during the test, use the following table to resolve the error.

Error	Solution
Bat 1 charge failed	Check that the power and communication cables between the battery and inverter are properly connected.
Bat 1 discharge failed	Check that the power and communication cables between the battery and inverter are properly connected.
Low SOE	Charge the battery to 20 percent SOE at least.
Battery comm. error	Check that the communication cables between the battery and inverter are properly connected.
Turn switch to On	Turn the inverter ON/OFF switch to ON.

Large Residential PV Systems

For residential sites with large PV systems, a StorEdge inverter and a SolarEdge single phase inverter may be installed together. The StorEdge inverter manages the battery and functions as a PV inverter, and the second inverter is used for production of the additional PV power. During power outages, the StorEdge inverter provides power to backed-up loads, and the second inverter remains shut down until the grid is back.

If the inverter connected to the battery only has a single RS485 bus, installation of an RS485 Plug-in is required. Refer to the RS485 Plug-in Installation Guide at: http://www.solaredge.com/files/pdfs/RS485_expansion_kit_installation_guide.pdf. For instructions on how to check if the inverter has a single RS485 bus or two, refer to *Appendix D – Check Number of RS485 Buses*.

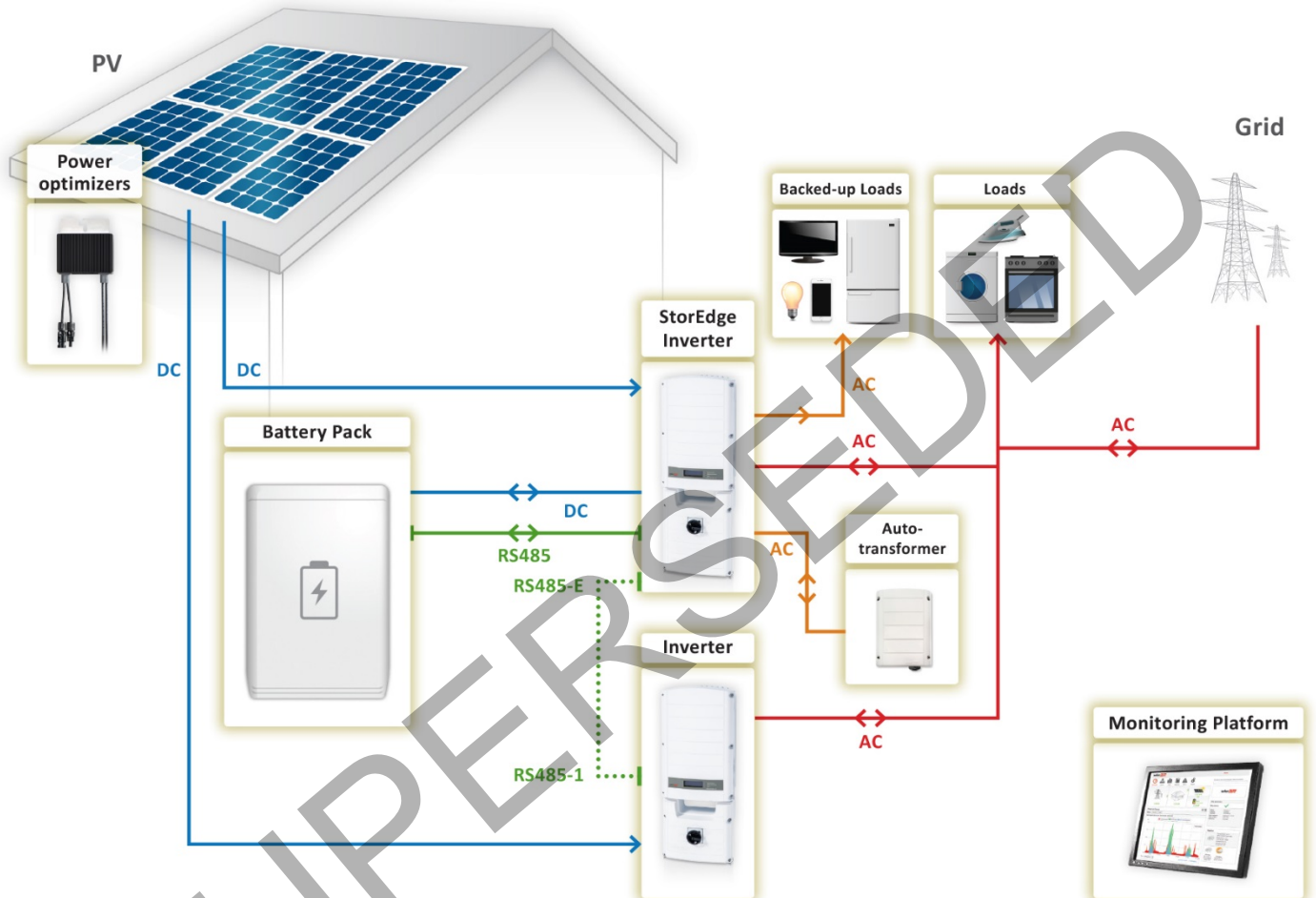

Figure 17: Backup Power Only - Large residential PV systems

► **To configure inverter RS485 communication:**

- 1 If needed, install the RS485 Plug-in in the inverter connected to the battery (the StorEdge inverter in Figure 17). If there is an RS485-2 port in the inverter, use it instead of the expansion kit. *The RS485-E port in the following instructions refers either to the Expansion port or to the RS485-2 port.*
- 2 Connect StorEdge inverter RS485-E port to SolarEdge standard inverter RS485-1 port using an RS485 twisted pair cable. Terminate both sides.
- 3 Select **Communication** → **RS485-E Conf** → **Enable**. Press Enter to continue.
- 4 Select **Protocol** → **Master**.
- 5 Select **Slave Detect**. Verify that the inverter reports the correct number of secondary inverters.
- 6 SolarEdge standard Inverter does not require communication configuration.

► **To configure the system:**

- 1 Configure the StorEdge inverter battery and backup power as described in *Basic Configuration* on page 23.
- 2 Configure the second SolarEdge inverter as described in <http://www.solaredge.com/files/pdfs/products/inverters/se-single-and-three-phase-inverter-user-manual-na.pdf>.

► **To verify communication:**

- Verify SolarEdge inverter communication as described in *Basic Configuration* on page 23.

► **To test the battery:**

- Test the battery as described in *Basic Configuration* on page 23.

Additional Capacity with Two Batteries

For sites where additional battery capacity is needed (for example, to enable backed-up loads to be powered from the batteries for longer periods), two batteries may be connected to a single StorEdge Inverter.

In this configuration, only one battery operates at any given time – i.e. the two batteries provide additional capacity only, not additional power.

For these installations, the two batteries must have a different part number and ID; both inverters require CPU version 3.2305 and above. If an upgrade is needed, refer to the StorEdge and Smart Energy Firmware Updates page at:

<https://www.solaredge.com/us/storedge/firmware>.

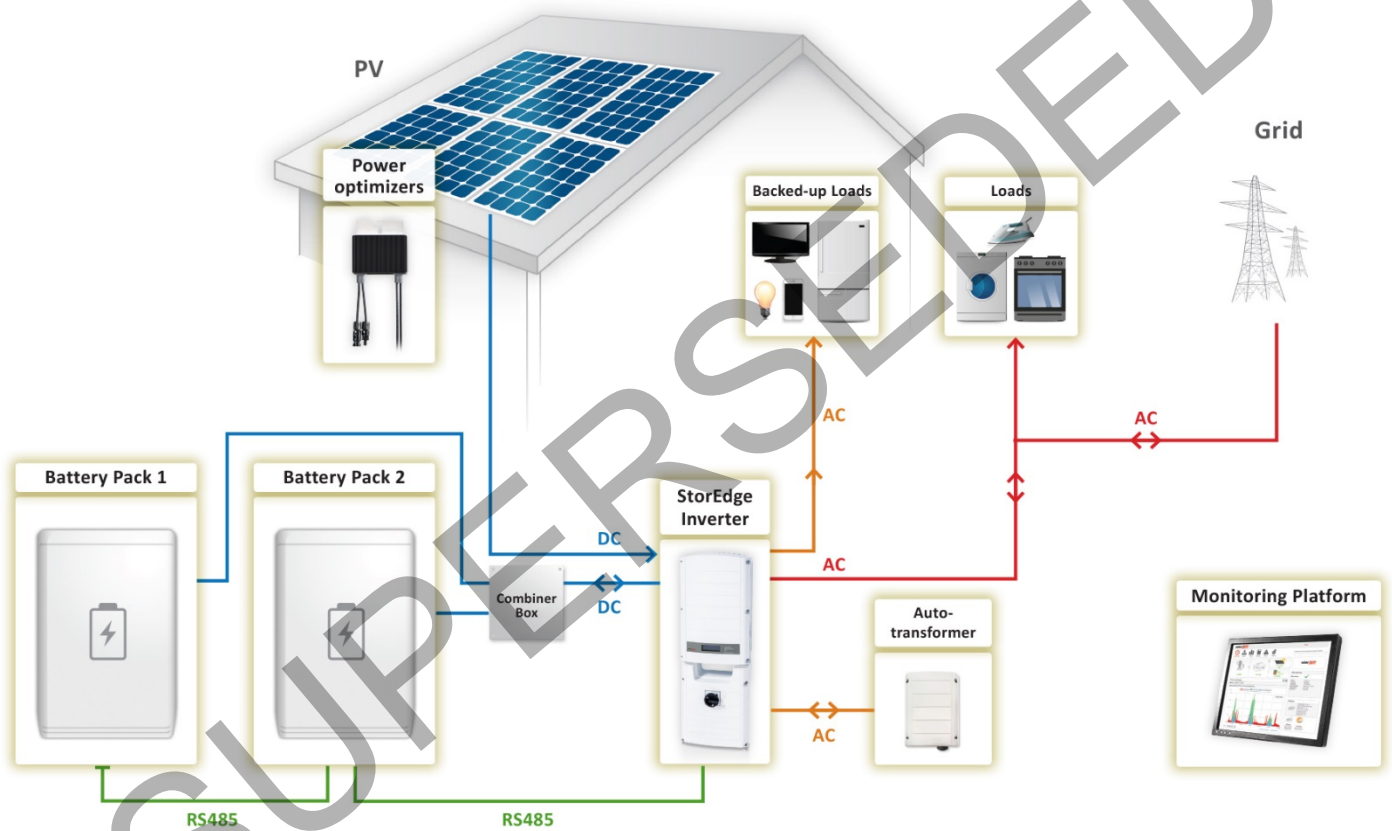

Figure 18: Backup Power Only - Additional capacity with two batteries

► **Configure the System:**

- 1 Configure Battery 1 and backup power as described in the *Basic Configuration* on page 9.
- 2 Configure Battery 2:
 - a. Select **Communication** → **RS485-1 Conf** → **Device Type** → **Multi-devices**. A list of devices is displayed.
 - b. Select **Battery 2**. The battery configuration screen is displayed.
 - c. Configure the battery: Select **Device Type** → **Battery Pack**.
 - d. Battery 2 is pre-configured to LG with device ID 14.

► **To verifying communication:**

- Verify communication as described in *Basic Configuration* on page 23.

► **To test the battery:**

- Test the battery as described in *Basic Configuration* on page 23.

Additional Capacity and Power with Multiple Inverters

For sites where additional capacity and power with multiple inverters are needed (for example, to enable more backed-up loads to be powered simultaneously), two StorEdge inverters and two batteries may be installed. Each battery connects through a separate StorEdge Inverter, and each inverter manages the battery and the PV connected to it. Backed-up loads are connected to each inverter through separate load panels and auto-transformers. The inverter connected to the meter operates as the system manager.

For these installations, both inverters require CPU version 3.2305 and above. If an upgrade is needed, refer to the StorEdge and Smart Energy Firmware Updates page at: <https://www.solaredge.com/us/storeedge/firmware>.

If the inverter connected to the battery only has a single RS485 bus, installation of an RS485 Plug-in is required. Refer to the RS485 Plug-in Installation Guide at: http://www.solaredge.com/files/pdfs/RS485_expansion_kit_installation_guide.pdf. For instructions on how to check if the inverter has a single RS485 bus or two, refer to *Appendix D – Check Number of RS485 Buses*.

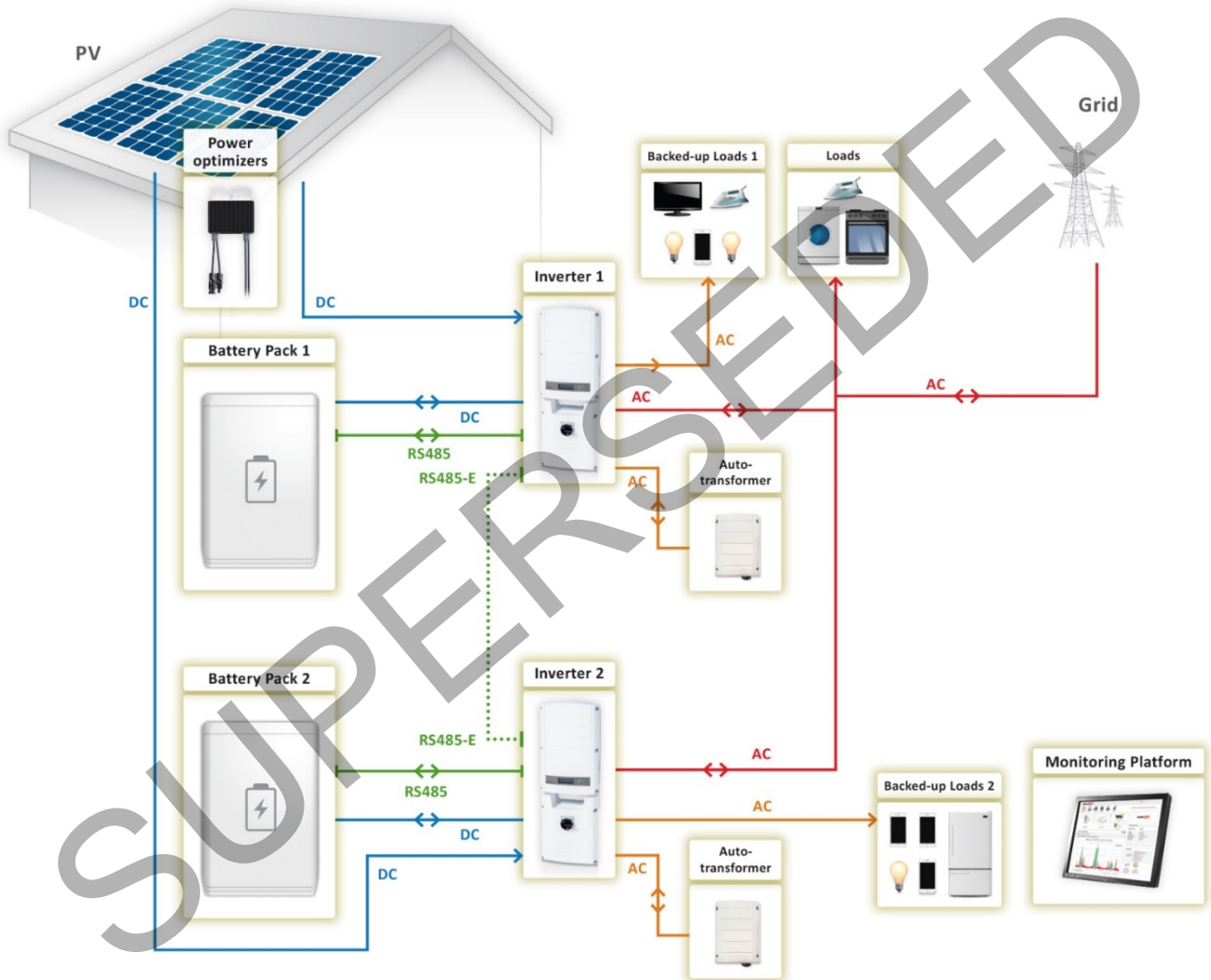

Figure 19: Additional capacity and power with multiple inverters

► To configure RS485 Communication:

- 1 If needed, install an RS485 Plug-in in each inverter. If there is an RS485-2 port in the inverter, use it instead of the expansion kit. *The RS485-E port in the following instructions refers either to the Expansion port or to the RS485-2 port.*
- 2 Connect the inverter 1 RS485-E port to the inverter 2 RS485-E port using an RS485 twisted pair cable. Make sure to terminate both sides (see Figure 5).
- 3 Configure inverter 2 RS485 Expansion port: Select **Communication** → **RS485-E Conf** → **Enable**.
- 4 Configure inverter 1 RS485 Expansion port:
 - a. Select **Communication** → **RS485-E Conf** → **Enable**. Press Enter to continue.
 - b. Select Protocol → **Master**.
- 5 Configure inverter 2 an RS485 Expansion port:

- a. Select **Communication** → **RS485-E Conf** → **Enable**. Press Enter to continue.
- b. Make sure that the connection is configured to Slave. Select **Protocol** → **Slave**
- c. Establish communication between inverter 1 and inverter 2:
 Select **Slave Detect** on inverter 1. Verify that the inverter reports the correct number of secondary inverters. It needs to be done before configuring secondary inverters.

► **To configure the inverters:**

- Configure the battery and backup power of both inverters as described in *Basic Configuration* on page 23.

► **To verify communication:**

- Verify communication of both inverters as described in *Basic Configuration* on page 23.

► **To test the battery:**

- Test the battery as described in *Basic Configuration* on page 23.

AC Coupling using a non-SolarEdge Inverter

For sites with an already installed PV system with a non-SolarEdge inverter, the StorEdge inverter can be AC-coupled to the existing inverter, i.e. the StorEdge inverter used to manage the battery is connected to the AC output of the existing inverter and charges the battery using the PV power produced by the non-SolarEdge inverter.



NOTE

The non-SolarEdge inverter production is not measured. The production information in the monitoring portal does not take into account this production.

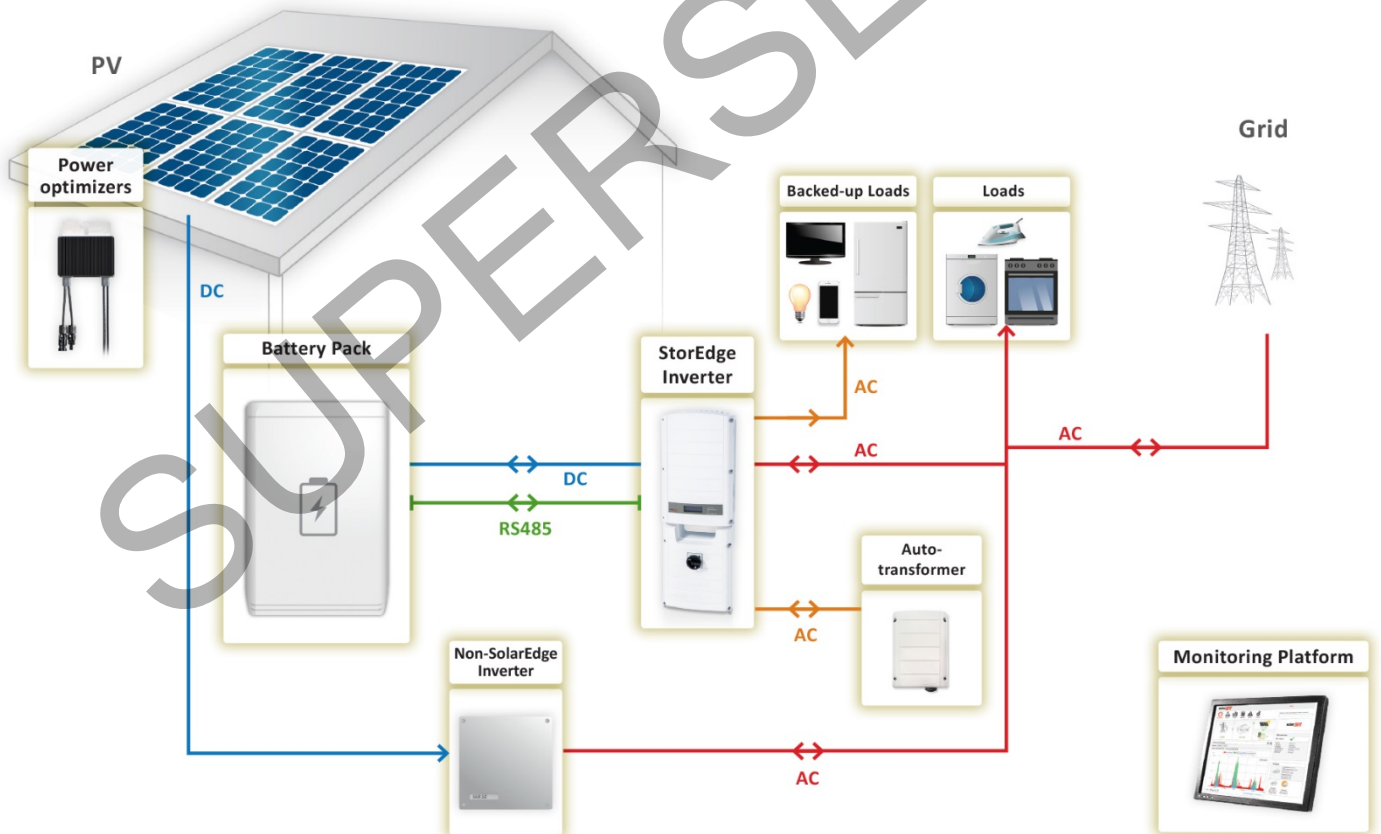

Figure 20: Backup Power Only - AC Coupling using a non-SolarEdge Inverter

► **To Configure the Meter and the Battery:**

- Configure the battery and backup power as described in the section *Basic Configuration* on page 23.

► **To Verify Communication:**

- Verify communication as described in the section *Basic Configuration* on page 23.

► **To test the battery:**

- Test the battery as described in *Basic Configuration* on page 23.

SUPERSEDED

Smart Energy Management Only - System Configurations

In this mode stored energy is used for Smart Energy Management applications only.

A Smart Energy Management only system can be upgraded to support backup power by installing an auto-transformer and connecting backed-up loads through a separate panel, and reconfiguring the system as described in the chapter *Smart Energy Management with Backup Power on page 2*.

Configuration is performed as described in the *Smart Energy Management with Backup Power - System Configurations* chapter, **without the section: To Set Up Backup Power**.

System Connection

The following diagram illustrates the connection of the system components when using the basic configuration for Smart Energy Management only: one StorEdge inverter, one meter and one battery. For enlarged segments of this diagram, refer to *Appendix E – Detailed System Connection Drawings*.

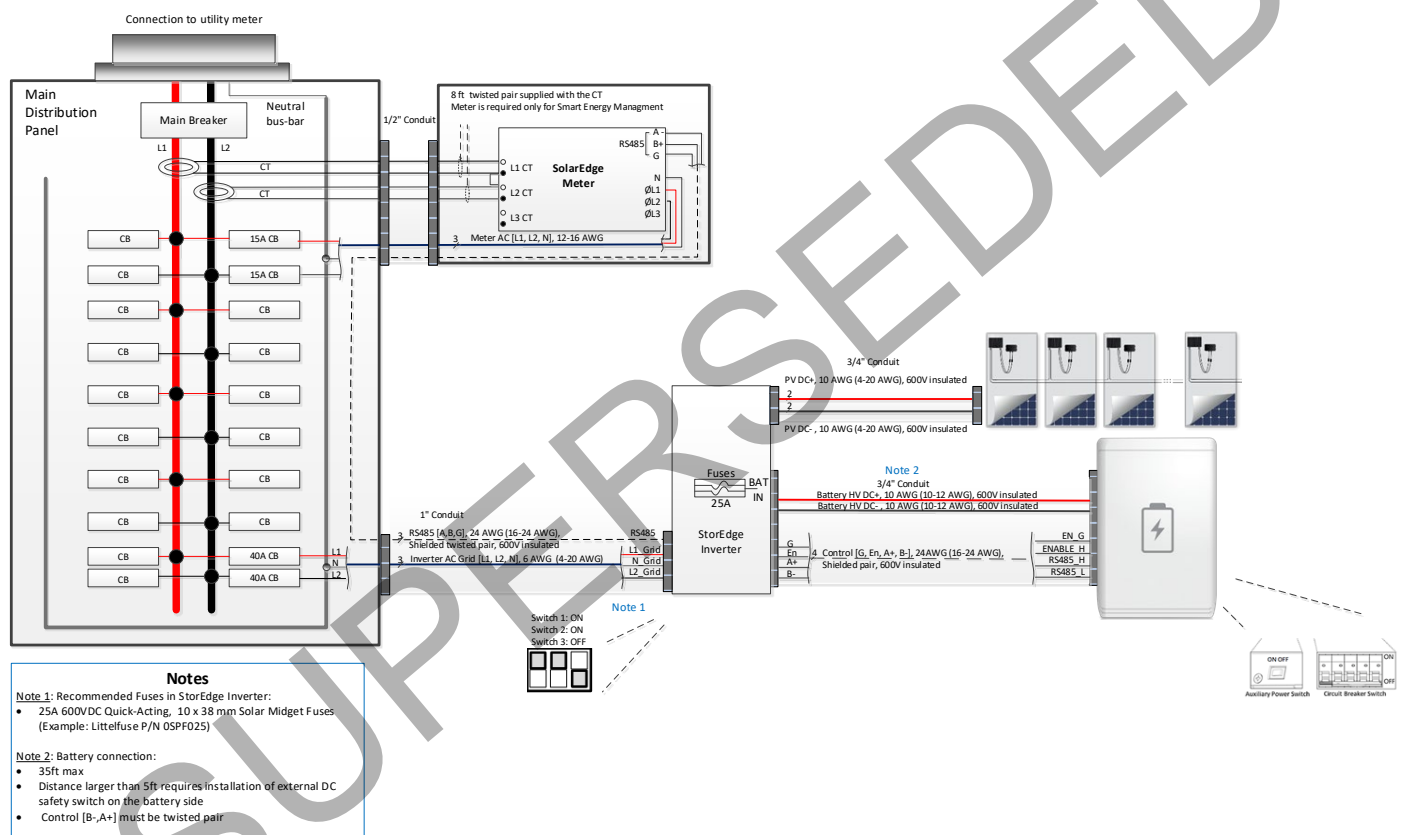

Figure 21: Smart Energy Management only - Basic Configuration

The following diagram illustrates the connection of the system components when using two batteries. In this case, an external combiner box is needed. For enlarged segments of this diagram refer to *Appendix E – Detailed System Connection Drawings*.

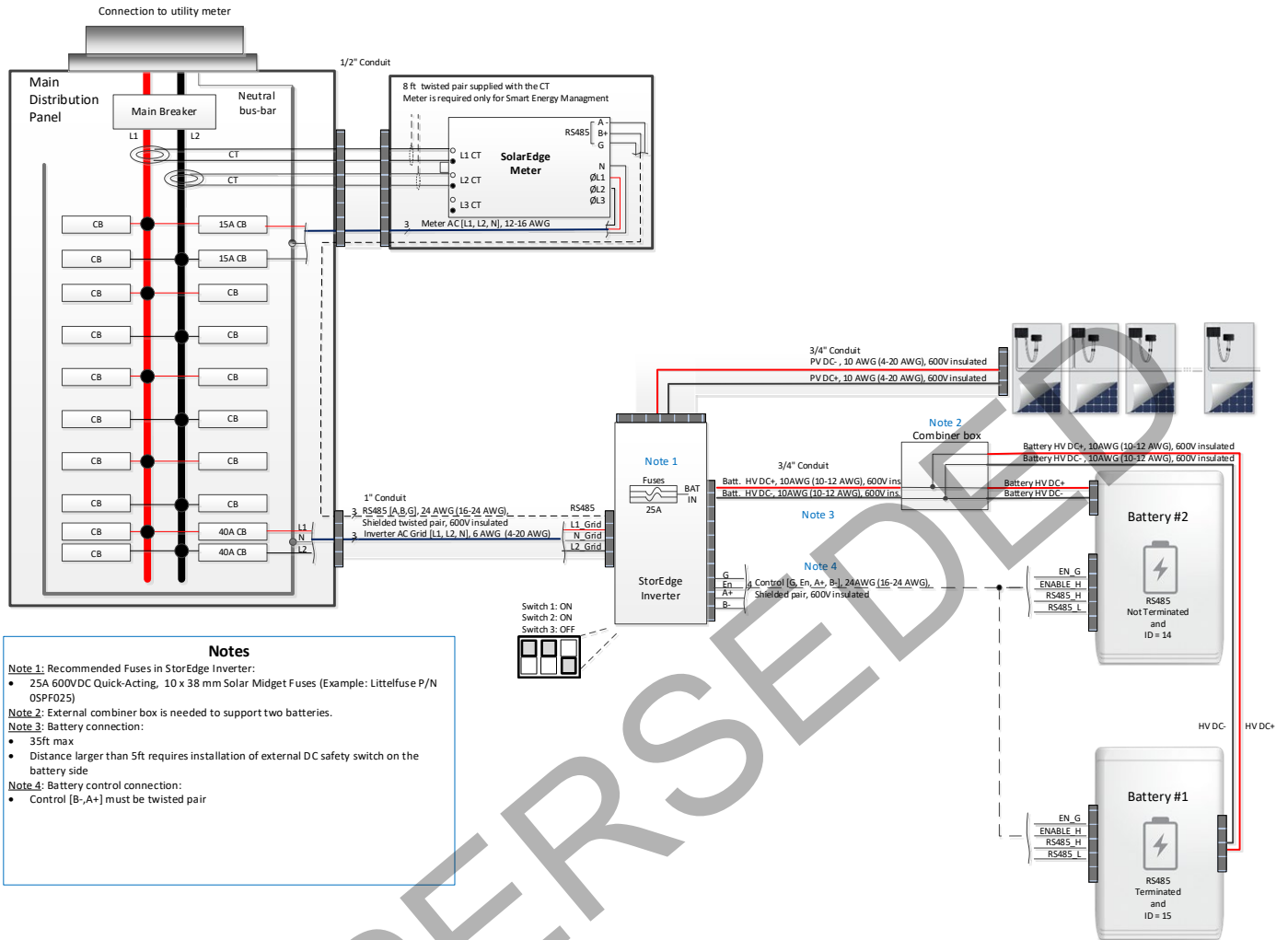

Figure 22: Smart Energy Management Only Using Two Batteries

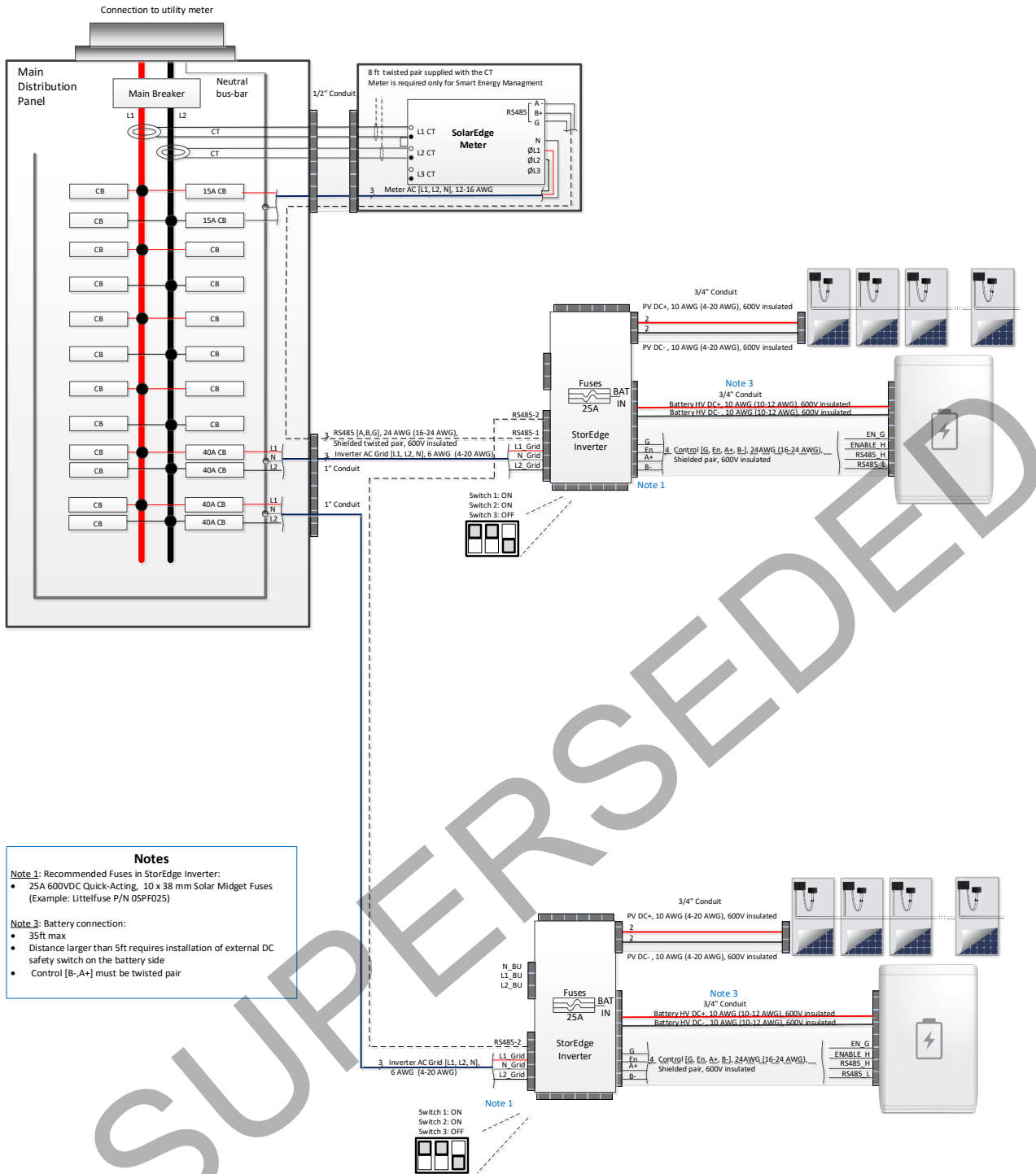

Figure 23: Smart Energy Management Only Using Two Inverters and Two Batteries

Basic Configuration

This configuration is based on one of each of the StorEdge components, other than the auto-transformer, and is suitable for most residential systems.

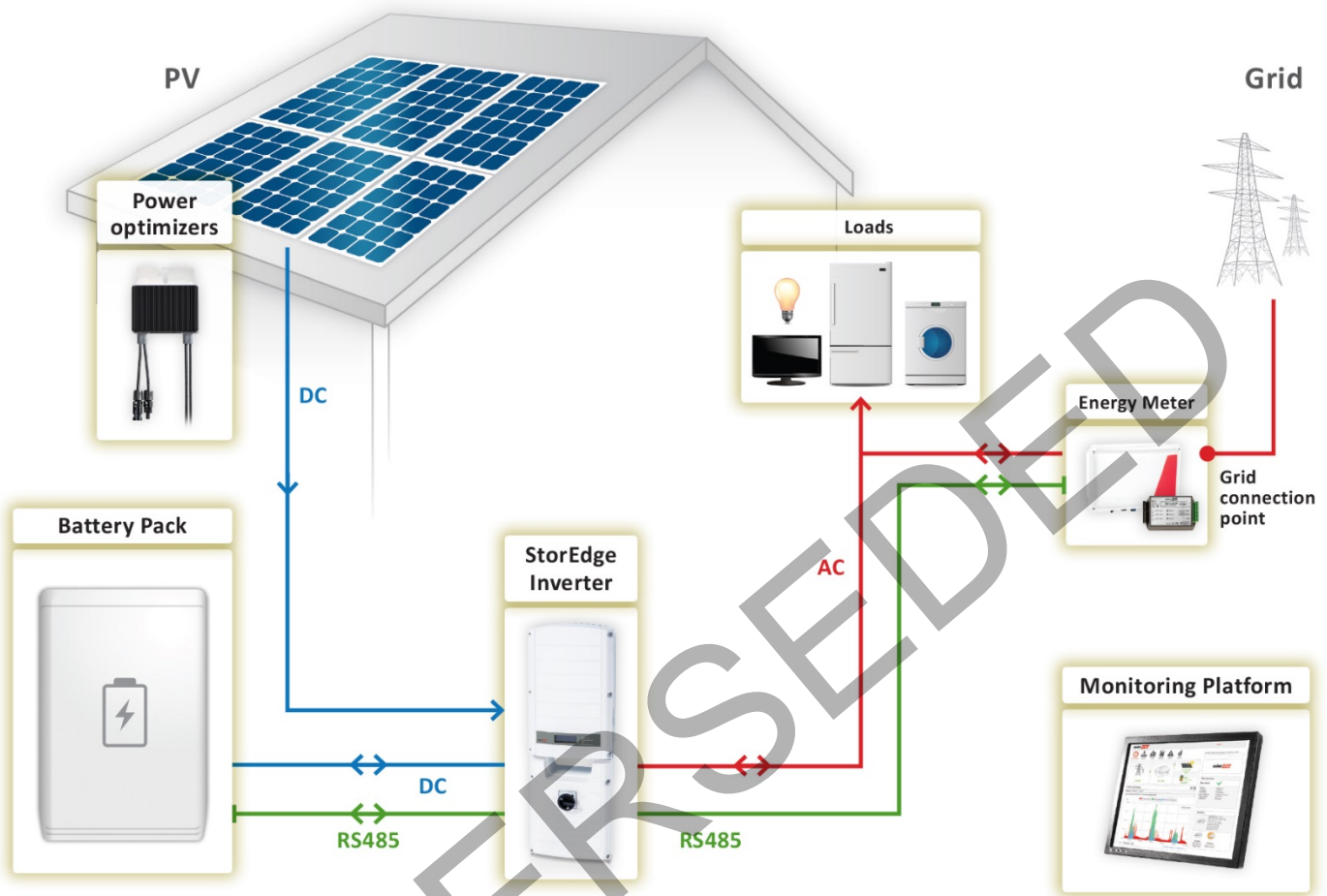

Figure 24: Smart Energy Management only - Basic configuration

Follow the steps provided in the *Basic Configuration* section of the chapter *Smart Energy Management with Backup Power* without setting up backup power.

Large Residential PV Systems

For residential sites with large PV systems, a StorEdge inverter and a SolarEdge single phase inverter may be installed together. The StorEdge inverter manages the battery and functions as a PV inverter, and the second inverter is used for production of the additional PV power.

If the inverter connected to the battery only has a single RS485 bus, installation of an RS485 Plug-in is required. Refer to the RS485 Plug-in Installation Guide at: http://www.solaredge.com/files/pdfs/RS485_expansion_kit_installation_guide.pdf. For instructions on how to check if the inverter has a single RS485 bus or two, refer to *Appendix D – Check Number of RS485 Buses*.

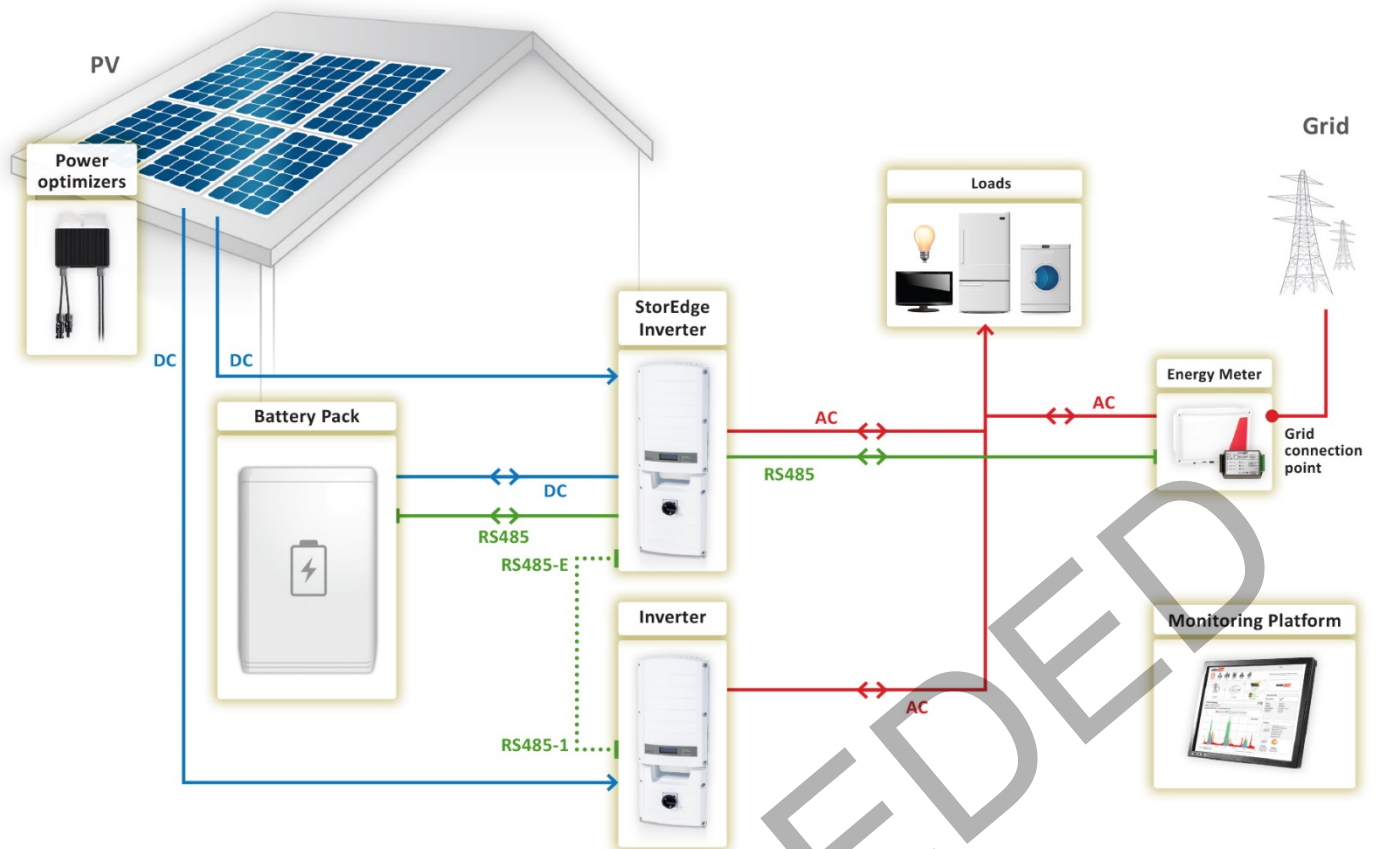

Figure 25: Smart Energy Management only - Large residential PV systems

Follow the steps provided in the *Large Residential PV Systems* section of the chapter *Smart Energy Management with Backup Power* without setting up backup power.

SUPERSEDED

Additional Capacity with Two Batteries

For sites where additional battery capacity is needed (for example, to enable backed-up loads to be powered from the batteries for longer periods), two batteries may be connected to a single StorEdge Inverter.

In this configuration, only one battery operates at any given time – i.e. the two batteries provide additional capacity only, not additional power.

For these installations, the two batteries must have a different part number and ID; both inverters require CPU version 3.2305 and above. If an upgrade is needed, refer to the StorEdge and Smart Energy Firmware Updates page at:

<https://www.solaredge.com/us/storedge/firmware>.

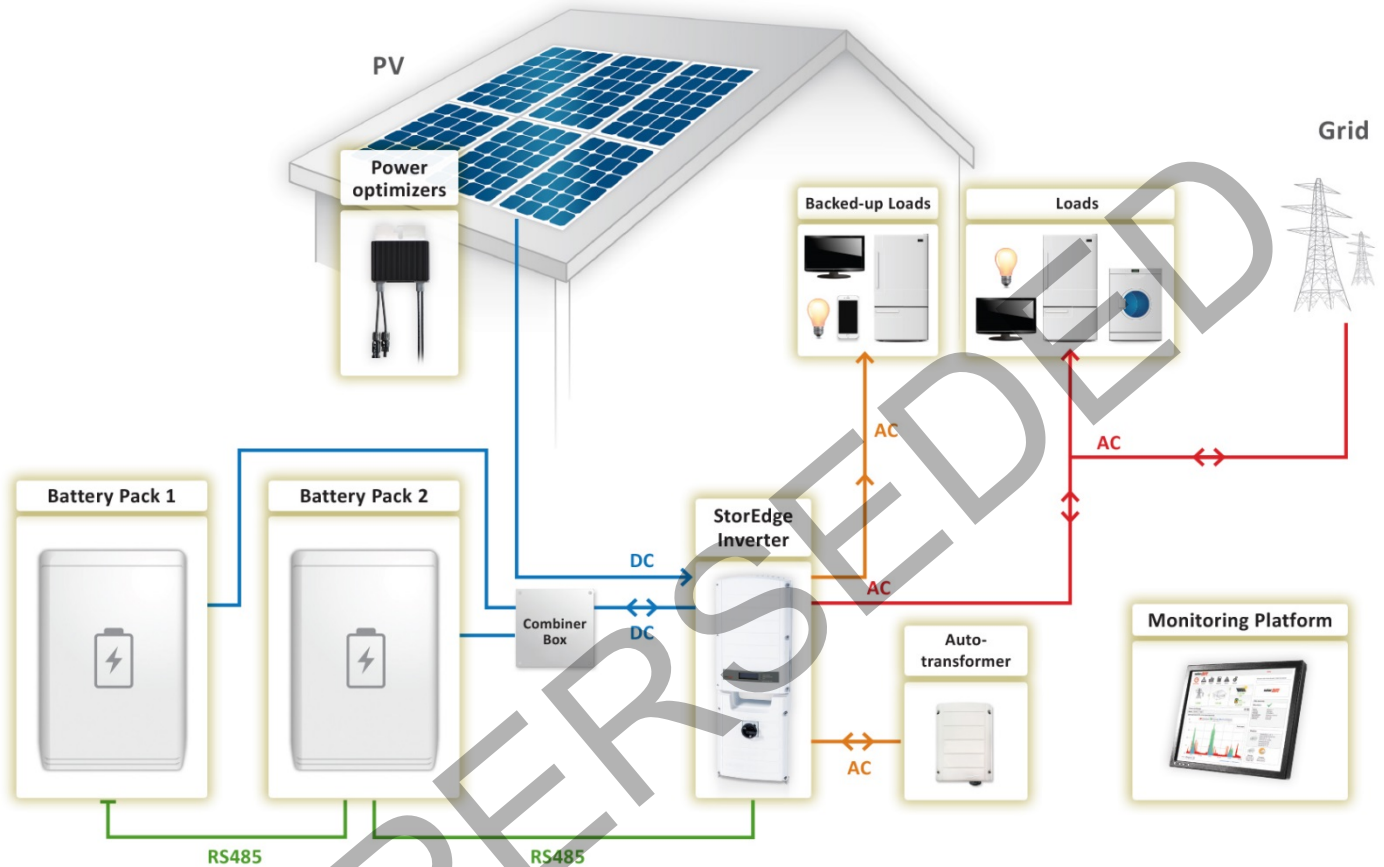

Figure 26: Smart Energy Management only - Additional capacity with two batteries

► To configure the system:

- 1 Configure Battery 1 and backup power as described in *Basic Configuration* on page 11.
- 2 Configure Battery 2:
 - a. Select **Communication** → **RS485-1 Conf** → **Device Type** → **Multi-devices**. A list of devices is displayed.
 - b. Select **Battery 2**. The battery configuration screen is displayed.
 - c. Configure the battery: Select **Device Type** → **Battery Pack**.
 - d. Battery 2 is pre-configured to **LG** with device ID **14**.

► To verify communication:

- Verify communication as described in in the section *Basic Configuration* on page 11.

► To test the battery:

- Test the battery as described in in the section *Basic Configuration* on page 11.

Additional Capacity and Power with Multiple Inverters

For sites where additional capacity and power with multiple inverters are needed (for example, to enable more backed-up loads to be powered simultaneously), two StorEdge inverters and two batteries may be installed. Each battery connects through a separate StorEdge Inverter, and each inverter manages the battery and the PV connected to it. Backed-up loads are connected to each inverter through separate load panels and auto-transformers. The inverter connected to the meter operates as the system manager.

If the inverter connected to the battery only has a single RS485 bus, installation of an RS485 Plug-in is required. Refer to the RS485 Plug-in Installation Guide at: http://www.solaredge.com/files/pdfs/RS485_expansion_kit_installation_guide.pdf. For instructions on how to check if the inverter has a single RS485 bus or two, refer to *Appendix D – Check Number of RS485 Buses*. For these installations, both inverters require CPU version 3.2305 and above. If an upgrade is needed, refer to the StorEdge and Smart Energy Firmware Updates page at: <https://www.solaredge.com/us/storedge/firmware>.

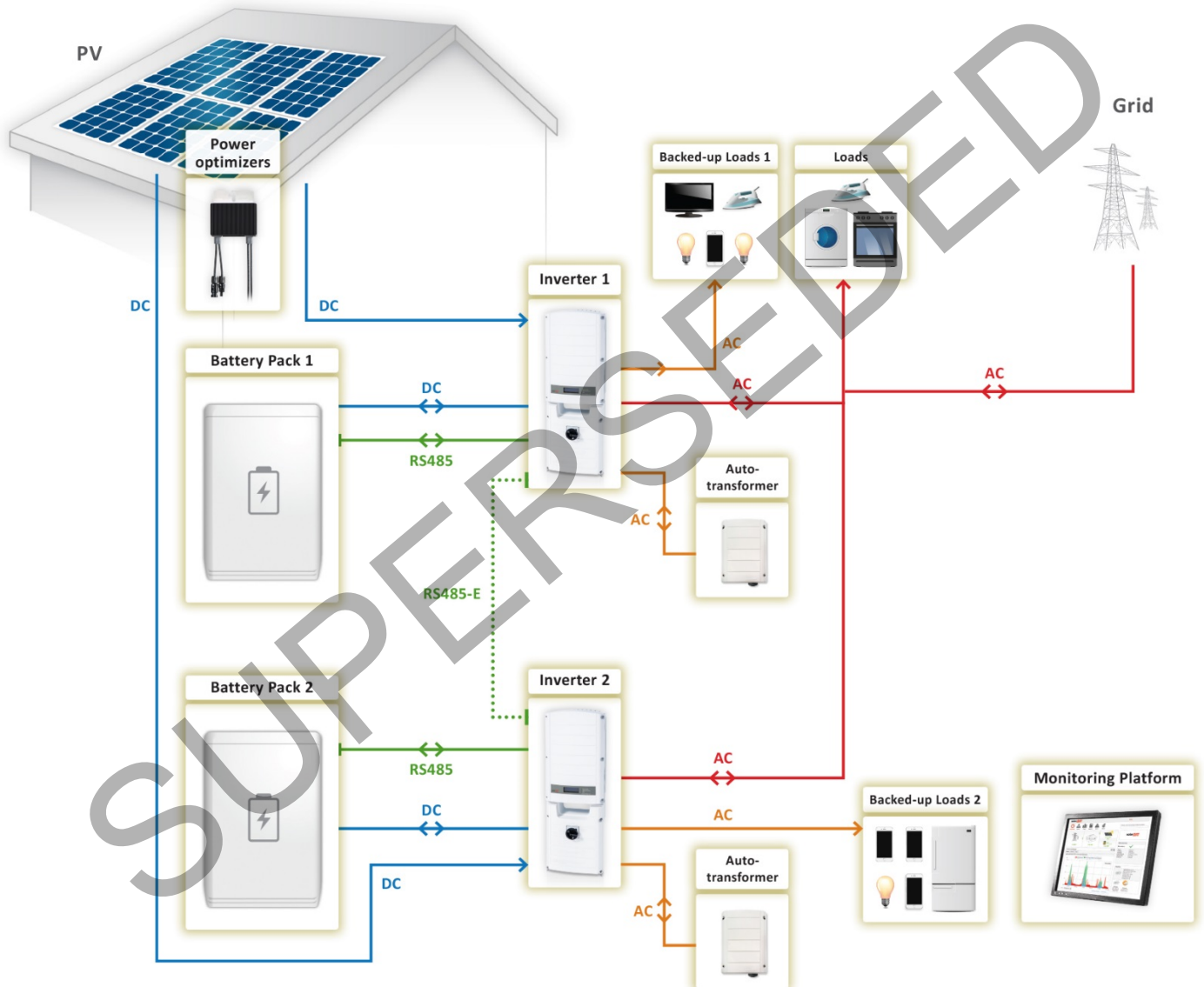

Figure 27: Smart Energy Management only – Additional capacity and power with multiple inverters

► To configure RS485 Communication:

- 1 If needed, install an RS485 Plug-in in each inverter. If there is an RS485-2 port in the inverter, use it instead of the expansion kit. *The RS485-E port in the following instructions refers either to the Expansion port or to the RS485-2 port.*
- 2 Connect the inverter 1 RS485-E port to inverter 2 RS485-E port using an RS485 twisted pair cable. Make sure to terminate both sides (see Figure 5).
- 3 Configure the inverter 2 RS485-E port: Select **Communication** → **RS485-E Conf** → **Enable**.
- 4 Configure the inverter 1 RS485-E port:
 - a. Select **Communication** → **RS485-E Conf** → **Enable**. Press Enter to continue.

b. Select Protocol → Master.

5 Configure the inverter 2 RS485-E port:

- a. Select **Communication** → **RS485-E Conf** → **Enable**. Press Enter to continue.
- b. Make sure that the connection is configured to Slave. Select **Protocol** → **Slave**
- c. Establish communication between inverter 1 and inverter 2:
- d. Select **Slave Detect** on inverter 1. Verify that the inverter reports the correct number of secondary inverters. It needs to be done before configuring secondary inverters.

► **To configure the inverters:**

- Configure the battery and backup power of both inverters as described in the *Basic Configuration* on page 11.

► **To verify communication:**

- Verify communication of both inverters as described in the *Basic Configuration* on page 11.

► **To test the battery:**

- Test the battery as described in in the section *Basic Configuration* on page 11.

AC Coupling using a non-SolarEdge Inverter

For sites with an already installed PV system with a non-SolarEdge inverter, the SolarEdge inverter can be AC-coupled to the existing inverter, i.e. the StorEdge inverter used to manage the battery is connected to the AC output of the existing inverter.



NOTE

The meter is used for Smart Energy Management and does not measure the non-SolarEdge inverter production. The production and self-consumption information in the monitoring portal does not take into account this production.

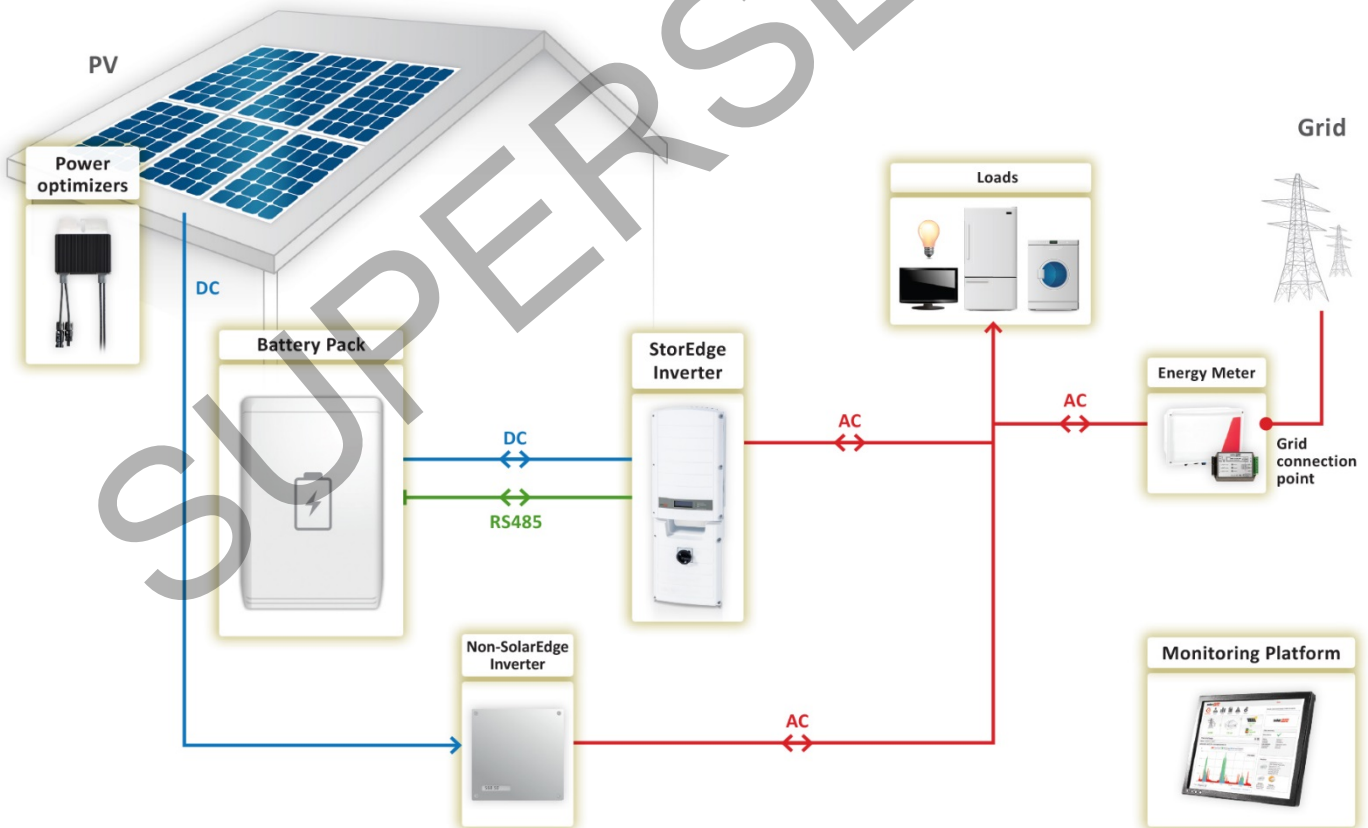

Figure 28: Smart Energy Management only - AC Coupling using a non-SolarEdge Inverter

► **To Configure the Meter and the Battery:**

- Configure the meter and the battery as described in the section *Basic Configuration* on page 11.

▶ **To Set Up Smart Energy Management:**

- After configuring the meter and the battery, proceed with maximizing self-consumption as described in the section *Basic Configuration* on page 11.

▶ **To Verify Communication:**

- Verify communication as described in the section *Basic Configuration* on page 11.

▶ **To test the battery:**

- Test the battery as described in in the section *Basic Configuration* on page 11.

SUPERSEDED

Appendix A – Creating a Charge/Discharge Profile

A charge/discharge profile is created from a yearly calendar, repeated for 20 years as long as no profile changes are made. The yearly calendar is divided into segments, with one of seven charge/discharge modes assigned to each segment.

A profile comprises three components:

- 1** A daily profile type: defines the charge/discharge modes throughout a day. Different day types may be defined, for example, winter weekday, spring weekday, weekend, holiday, etc.
- 2** A seasonal profile: defines weekly profiles to use during specified periods of the year. These periods must cover the entire year. A typical use case is creating seasonal profiles corresponding to the seasonal changes of electricity rates.
- 3** Special day type: defines dates that should have a specific daily profile instead of the profile defined for the relevant period. For example, if you defined a seasonal profile from Dec. 15 to Jan. 15 but want the system to have a different daily profile for New Years, define a special day. Special days can be set as one-time events or as recurring events.

Charge/Discharge Modes

Table 1: Charge/Discharge Modes

Mode	Description	Example Use case
PV only	No battery charging/discharging; for using the system without StorEdge capabilities	To avoid excess battery charge/discharge and prolong battery life
Charge from clipped PV	If PV production > inverter maximum production for self-consumption and grid export (up to the grid export limit and never more than inverter nameplate power), charge the battery	When grid export tariff and PV production are high; for example, during the summer and peak daytime production
Charge from PV	Charge battery from PV production until it is full, and only then use PV production for self-consumption and grid export	When import rate and PV production are low; for example, during the winter and afternoon
Charge from PV and grid	Charge battery from PV production and grid power (if needed) until it is full. Only then use PV production for self-consumption and grid export	When import rate is low and when AC charge is allowed by local regulations
Discharge to maximize export	If PV production < inverter maximum production (nameplate or limited power), discharge battery for self-consumption and grid export until the inverter reaches its power limit	When grid export tariff is high and PV production is not enough for self-consumption and grid export
Discharge to minimize import	If PV production < consumption, discharge battery only for self-consumption, not for grid export	When grid export is not allowed
Maximize self-consumption	Use PV production for self-consumption, then charge/discharge battery as needed to maximize self-consumption	When grid export tariffs are low or export is not allowed; reduce grid dependency

Creating a Profile

This procedure can be completed before the system is installed or connected to the portal, that is, the site was defined in the monitoring portal but not connected.

► **To create a profile:**

- Perform steps 1-9 in the procedure, “To create a storage profile” in the application note: *Charge/Discharge Profile Programming through the Monitoring Portal – Application Note*, at: https://www.solaredge.com/sites/default/files/storedge_charge_discharge_profile_programming.pdf

Appendix B – Verifying StorEdge Functionality

After system installation and configuration is completed, verify that the system is properly operating:

► Verify the meter function:

- 1 Make sure other power sources (e.g. non-SolarEdge PV inverter) are not producing power.
- 2 Verify the AC is ON.
- 3 Check the meter installed at the grid connection point:
 - a. Turn the inverter ON/OFF switch to OFF.
 - b. Connect loads on one of the measured phases.
 - c. Press the external LCD light button to display the Import or Export meter status screen, and check that the import or export power is greater than zero:

```
Import Meter
Status:      <OK/Error>
Power [W]:   xxxxx.x
Energy [Wh]: xxxxx.x
```

- d. Press the LCD light button to display the Export meter status screen, and check that the Export power is equal to zero. If it is not equal to zero check the CT direction on all connected phases.

► Verify maximized self-consumption:

- 1 Verify the inverter ON/OFF switch is ON.
- 2 Turn on as many loads as needed so that consumption will be greater than the inverter's maximum AC power. In the inverter LCD check that the Meter status screen is displaying import power greater than zero.
- 3 Press the inverter LCD light button to display the Smart Energy Management and the Battery status screens, and check that:
 - a. **State** = Discharging (assuming consumption > PV production, inverter maximum AC power > PV production)
 - b. **PWR** > 0

```
BSN: XXXXXXXXXXXX ID:24
SOE: 89%          PWR: 2W
Total: <x>Wh
State: Discharging
```

- 4 While the PV modules are exposed to sunlight, verify that the battery is charging properly:
 - a. Minimize consumption by turning off all the load circuit breakers, except for the inverter.
 - b. In the inverter LCD check that the Meter status screen is displaying import power close to zero.
 - c. Press the external LCD light button to display the Battery status screen, and check that:
 - iii. **State** = Charging
 - iv. **SOE** percentage is increasing
 - v. **PWR** > 0

```
BSN: XXXXXXXXXXXX ID:24
SOE: 89%          PWR: 2W
Total: <x>Wh
State: Charging
```

Appendix C – StorEdge Inverter without a Battery

The StorEdge inverter can be used without a battery as a PV inverter with no StorEdge applications. The system can be upgraded to support StorEdge applications by adding the remaining system components.

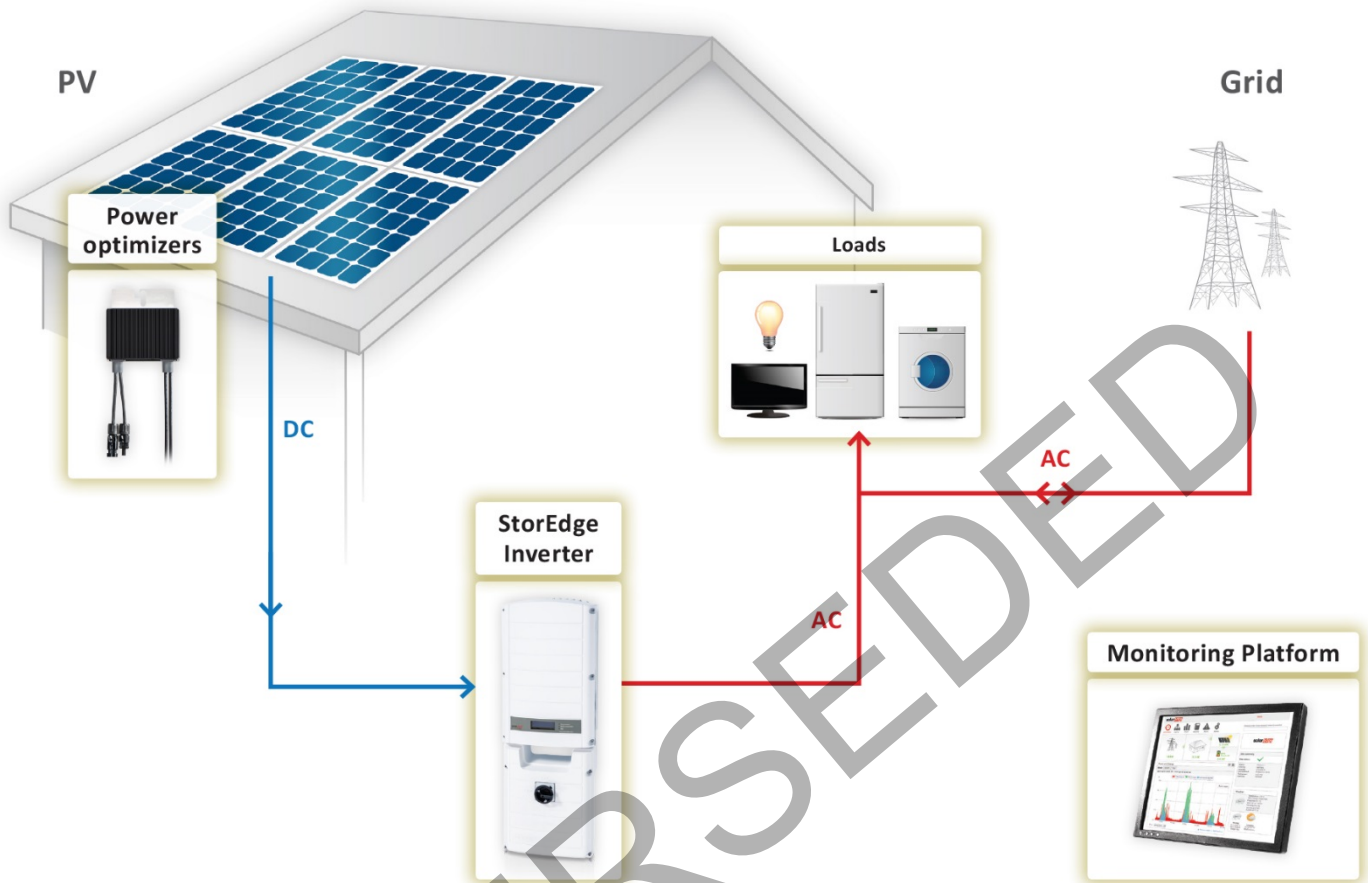

Figure 29: StorEdge inverter without a battery

► To connect and configure the system:

StorEdge inverter installation and AC and DC connections should be done as described in the StorEdge inverter manual supplied with it. StorEdge inverter configuration should be done according to the SolarEdge Installation Guide

<http://www.solaredge.com/files/pdfs/products/inverters/se-single-and-three-phase-inverter-user-manual-na.pdf>.

Appendix D – Check Number of RS485 Buses

If the inverter connected to the battery has only a single RS485 bus, or the system has a third-party controller, installation of an RS485 Plug-in is required. The kit provides an additional RS485 port within the inverter for connection.

► **To check the number of RS485 buses in the inverter:**

1 Select **Communication**.

2 If the inverter has two RS485 buses, an RS485-2 port configuration option will appear on the screen:

```
Server <LAN>
LAN Conf
RS485-1 Conf <M>
RS485-2 Conf <S>
```

3 If the inverter has a single RS485 bus, the RS485-2 port configuration option will *not* appear on the screen:

```
Server <LAN>
LAN Conf
RS485-1 Conf <M>
Cellular Conf <N/A>
```

4 To install an RS485 Plug-in, refer to the RS485 Plug-in Installation Guide at:

http://www.solaredge.com/files/pdfs/RS485_expansion_kit_installation_guide.pdf

SUPERSEDED

Appendix E – Detailed System Connection Drawings

Smart Energy Management with Backup Power – Basic Configuration

The detailed system connection drawings in this Appendix are based on the [basic Smart Energy Management with Backup Power configuration](#).

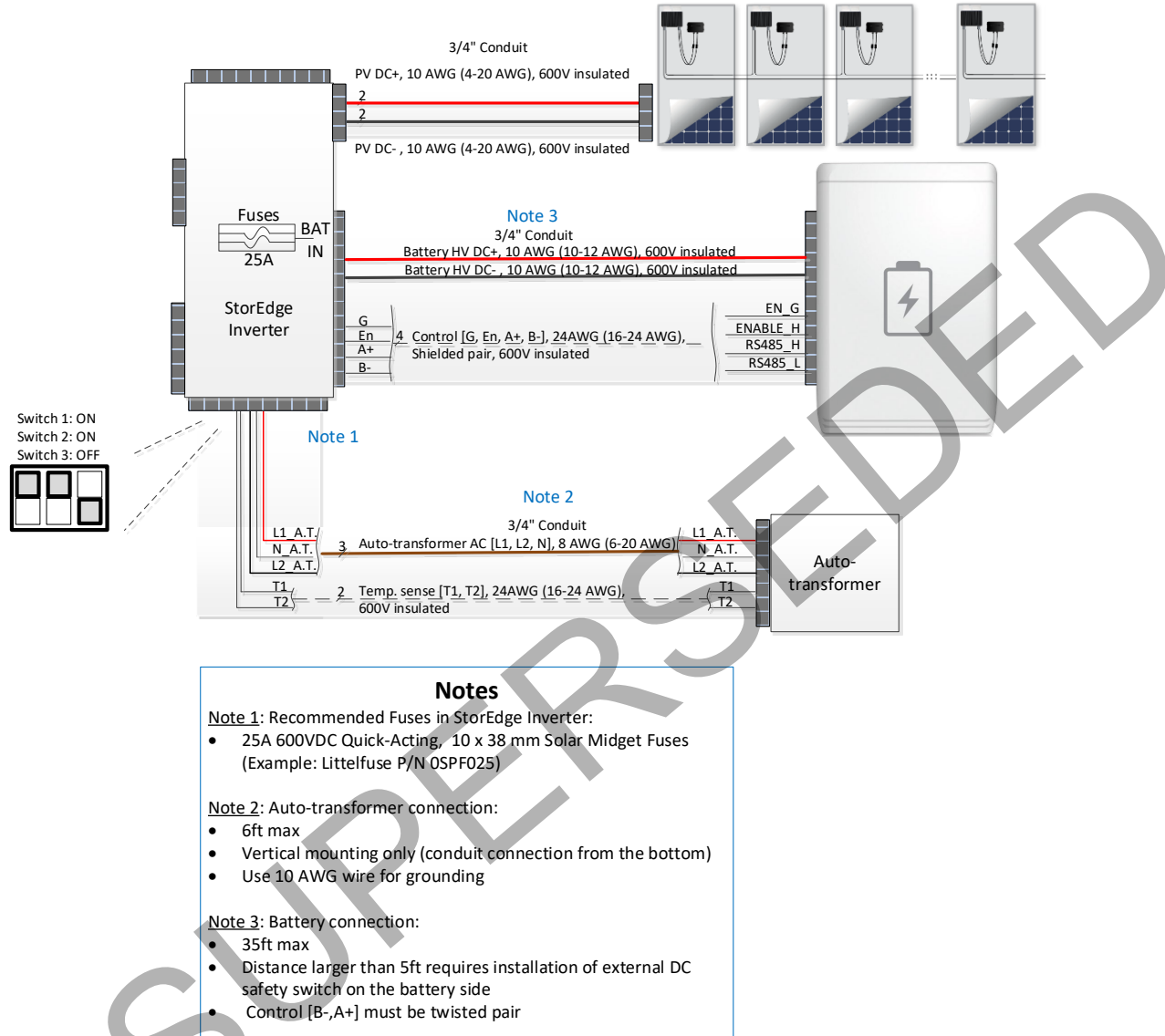

Figure 30: Basic Configuration – StorEdge Inverter, Power Optimizers, Battery, and Auto-transformer

Notes

Note 4: Install type B 2-pole 25A main circuit breaker to ensure the 25A phase limit imbalance is maintained at all times.

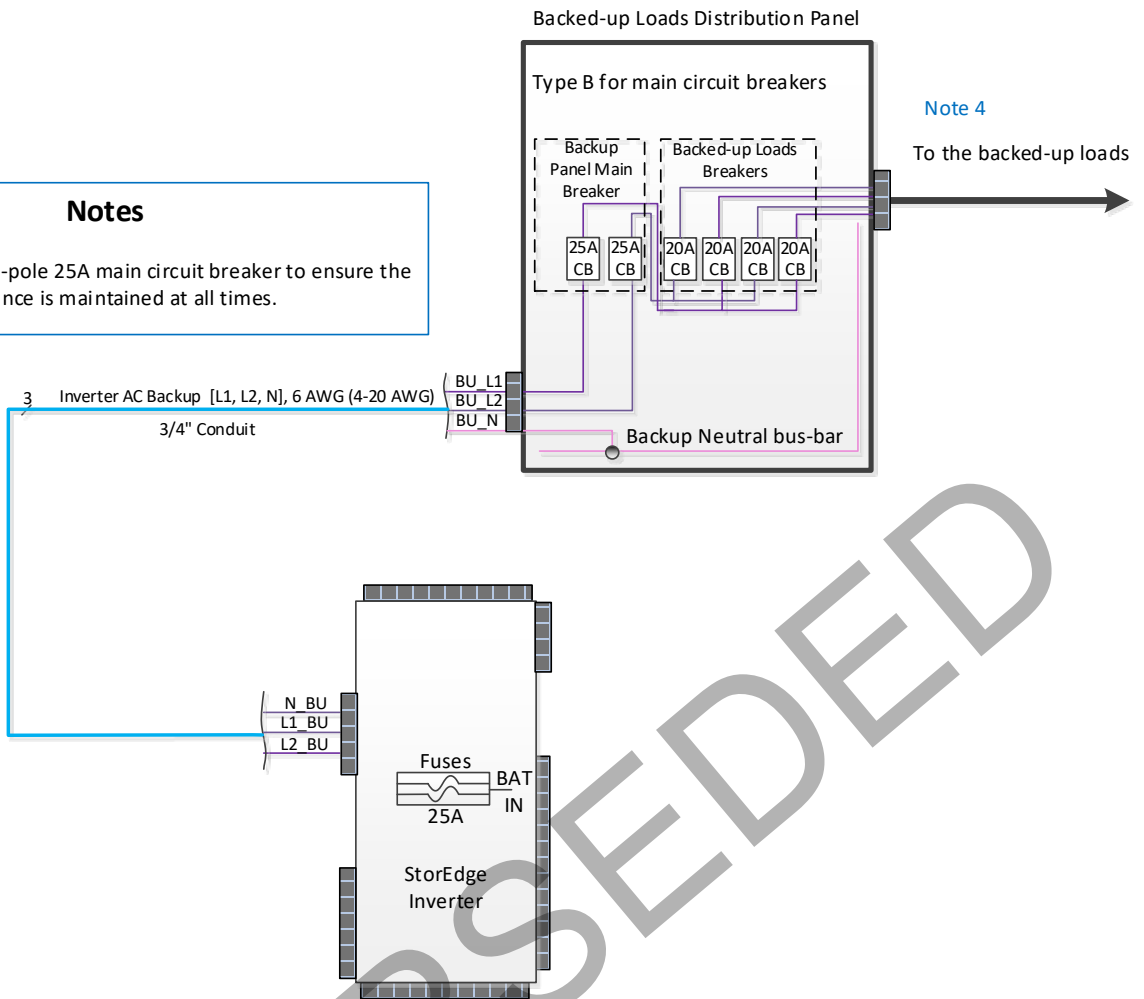

Figure 31: Basic Configuration – StorEdge Inverter and Backed-up Loads Distribution Panel

SUPERSEDED

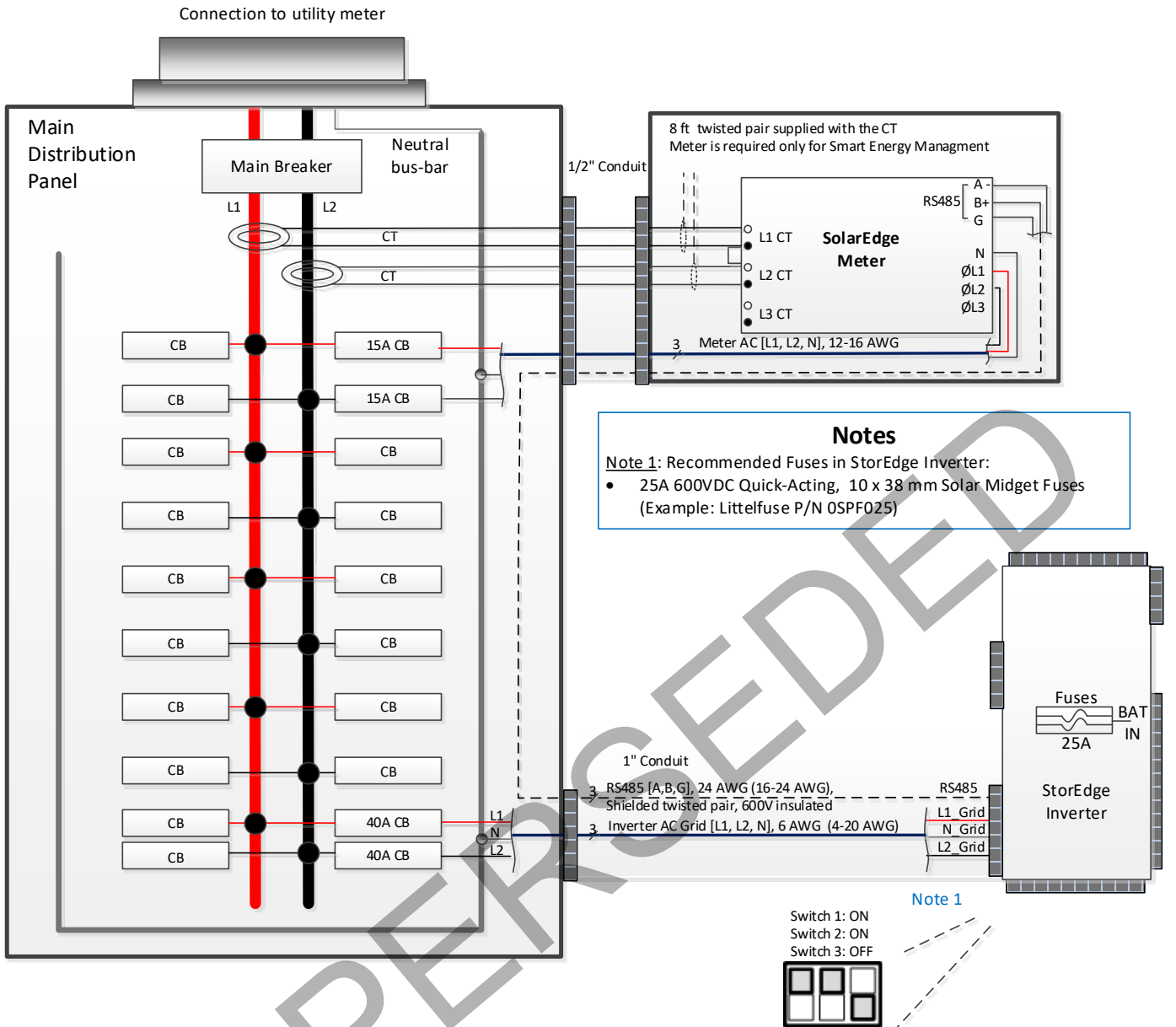

Figure 32: Basic Configuration – StorEdge Inverter, Meter, and Main Distribution Panel

Smart Energy Management with Backup Power – Basic Configuration (2 Battery)

The detailed system connection drawings in this Appendix are based on the [basic Smart Energy Management with Backup Power configuration for two batteries](#).

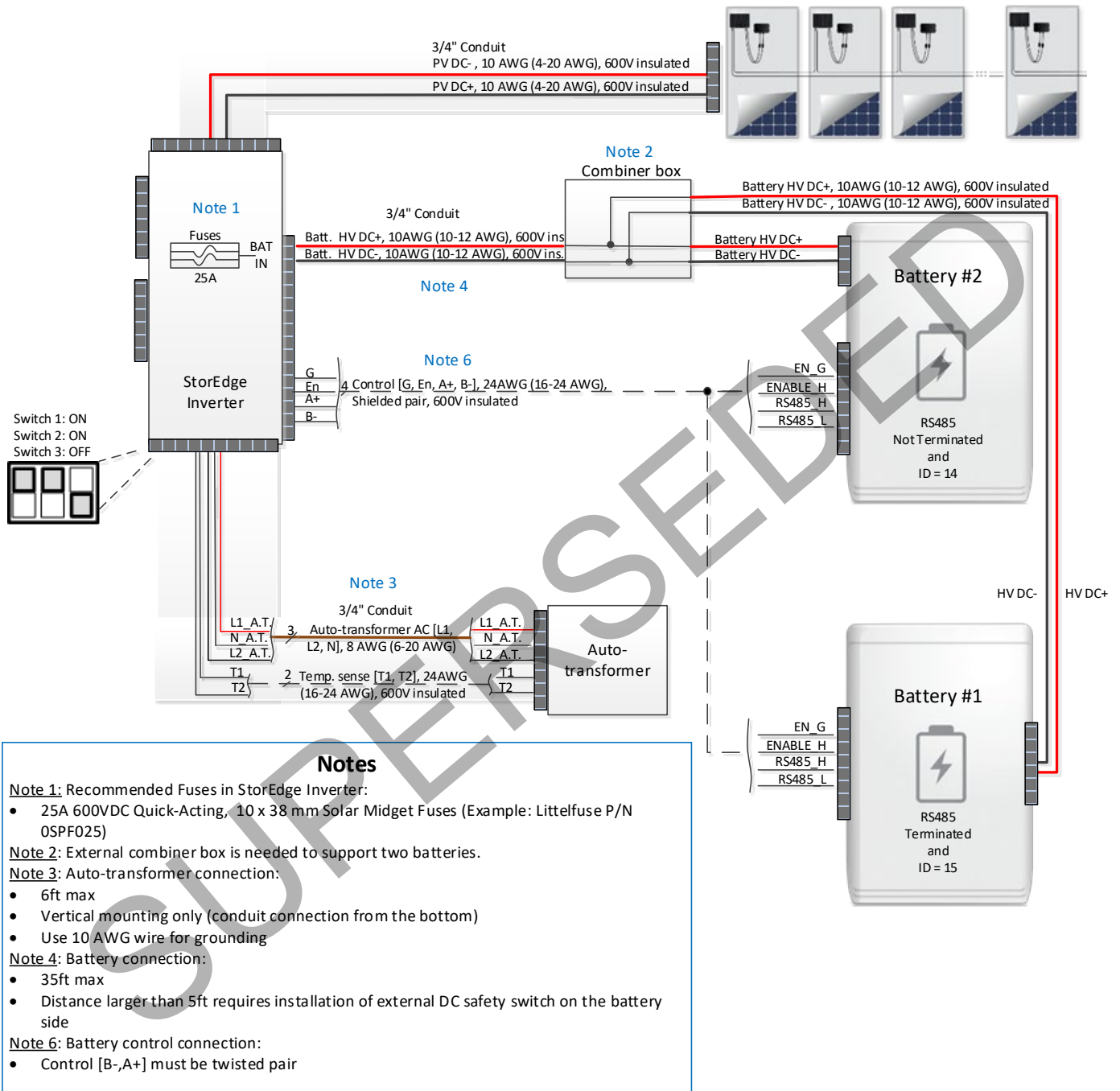

Figure 33: Basic Two-Battery Configuration – StorEdge Inverter, Power Optimizers, Batteries, and Auto-transformer

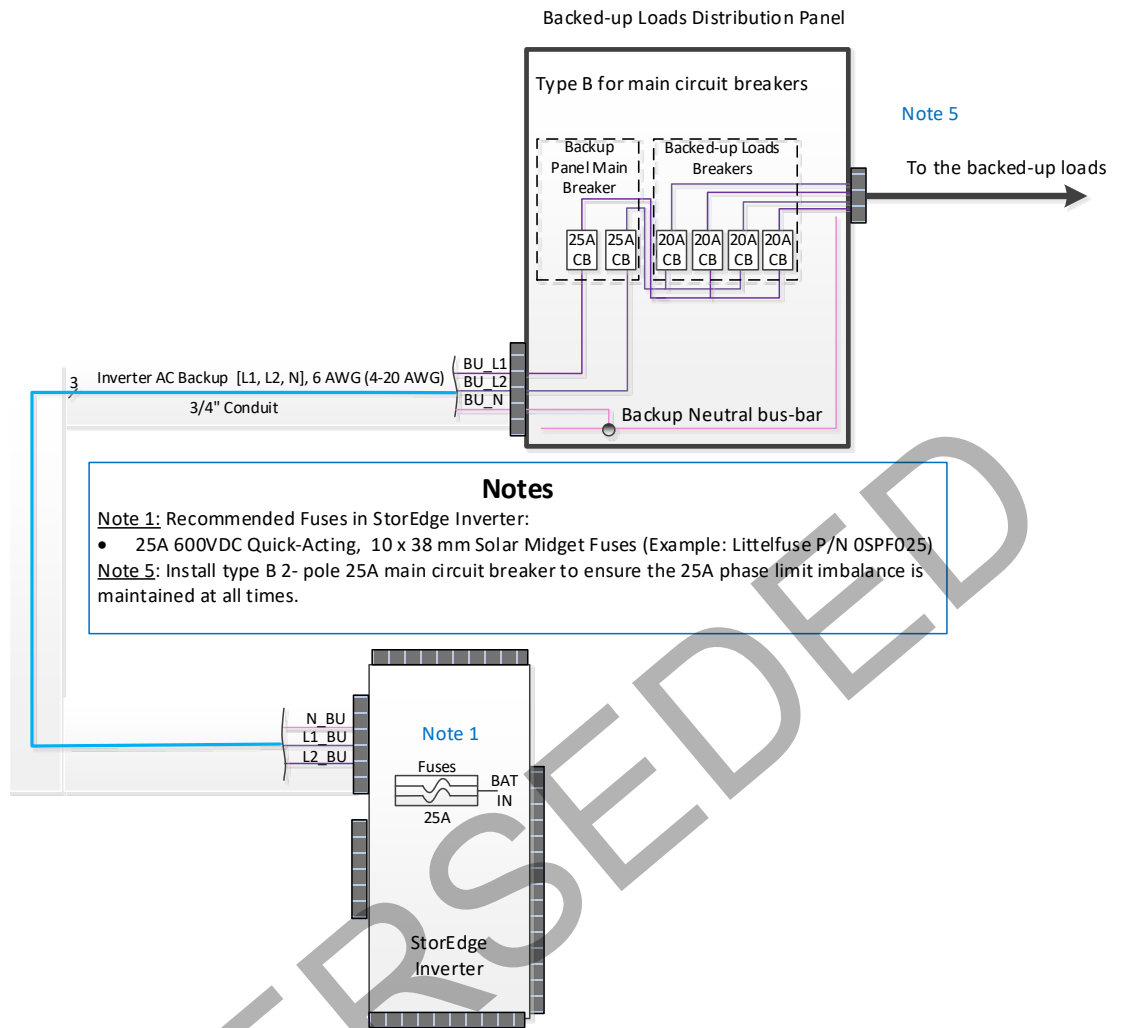

Figure 34: Basic Two-Battery Configuration – StorEdge Inverter and Backed-up Loads Distribution Panel

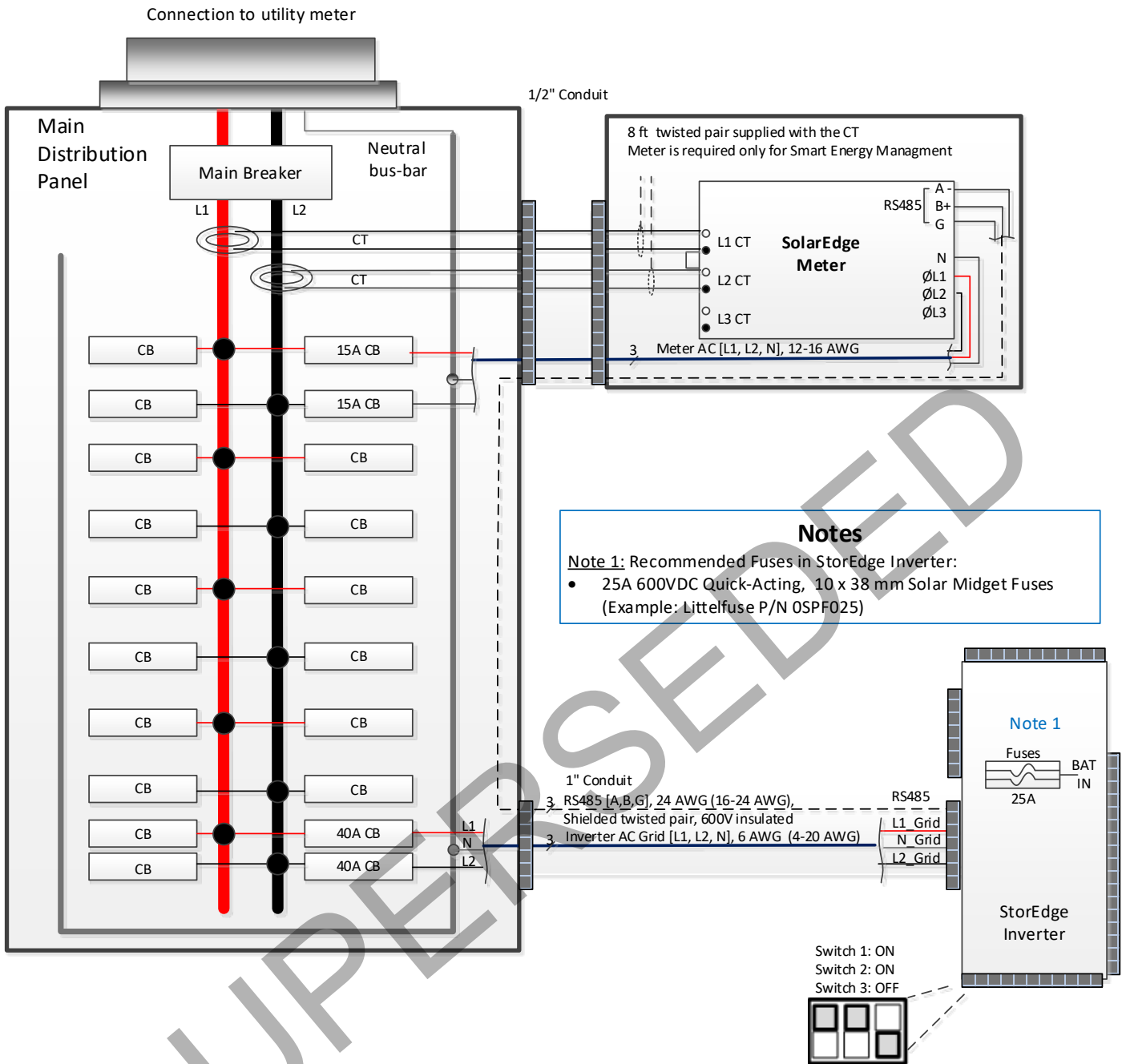

Figure 35: Basic Two-Battery Configuration – StorEdge Inverter, Meter, and Main Distribution Panel

Smart Energy Management with Backup Power – Basic Configuration (Two Inverters and Two Batteries)

The detailed system connection drawings in this Appendix are based on the [basic Smart Energy Management with Backup Power configuration for two inverters and two batteries](#).

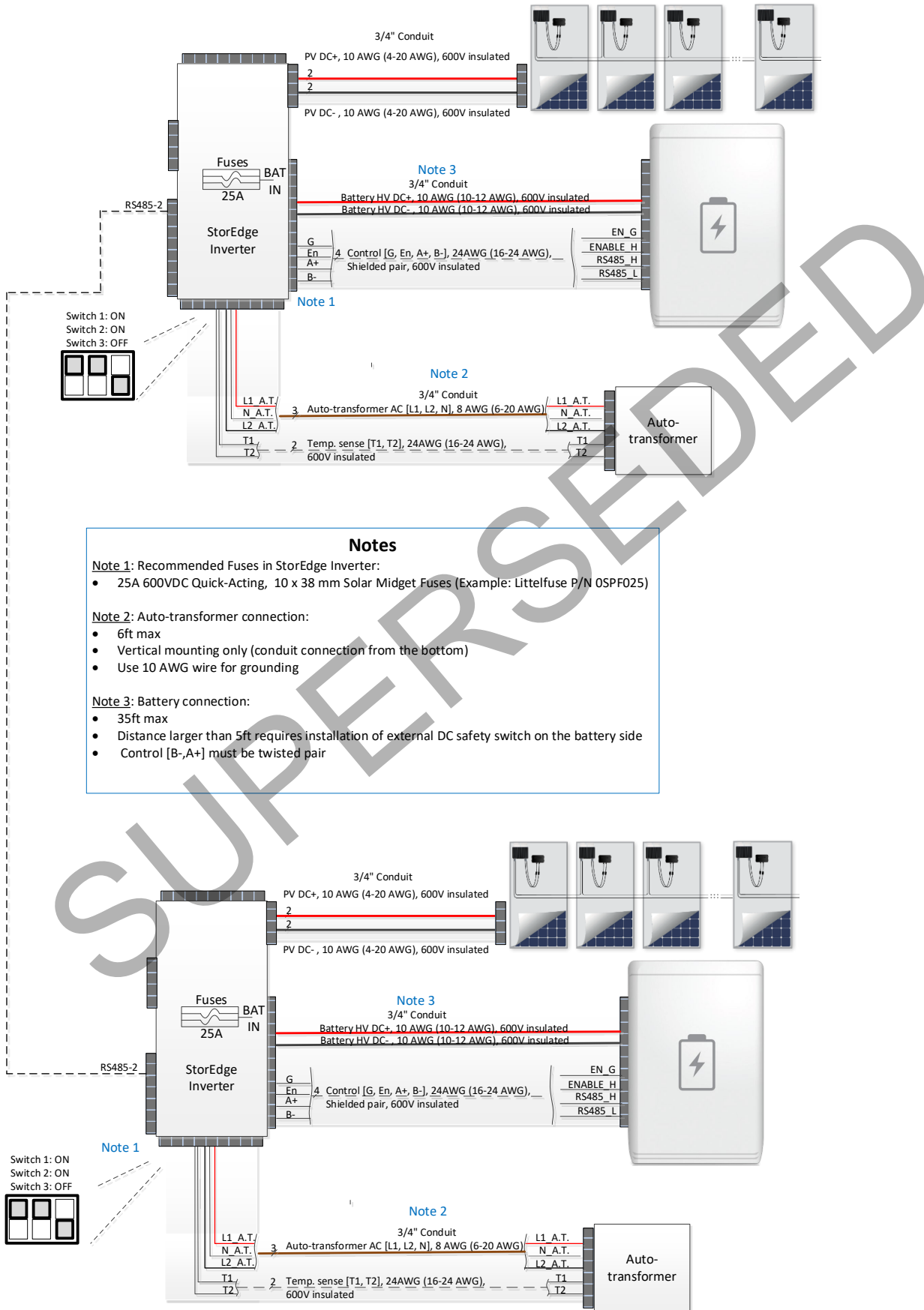

Figure 36: Basic 2-Inverter 2-Battery Configuration – StorEdge Inverter, Power Optimizers, Batteries, Auto-transformer

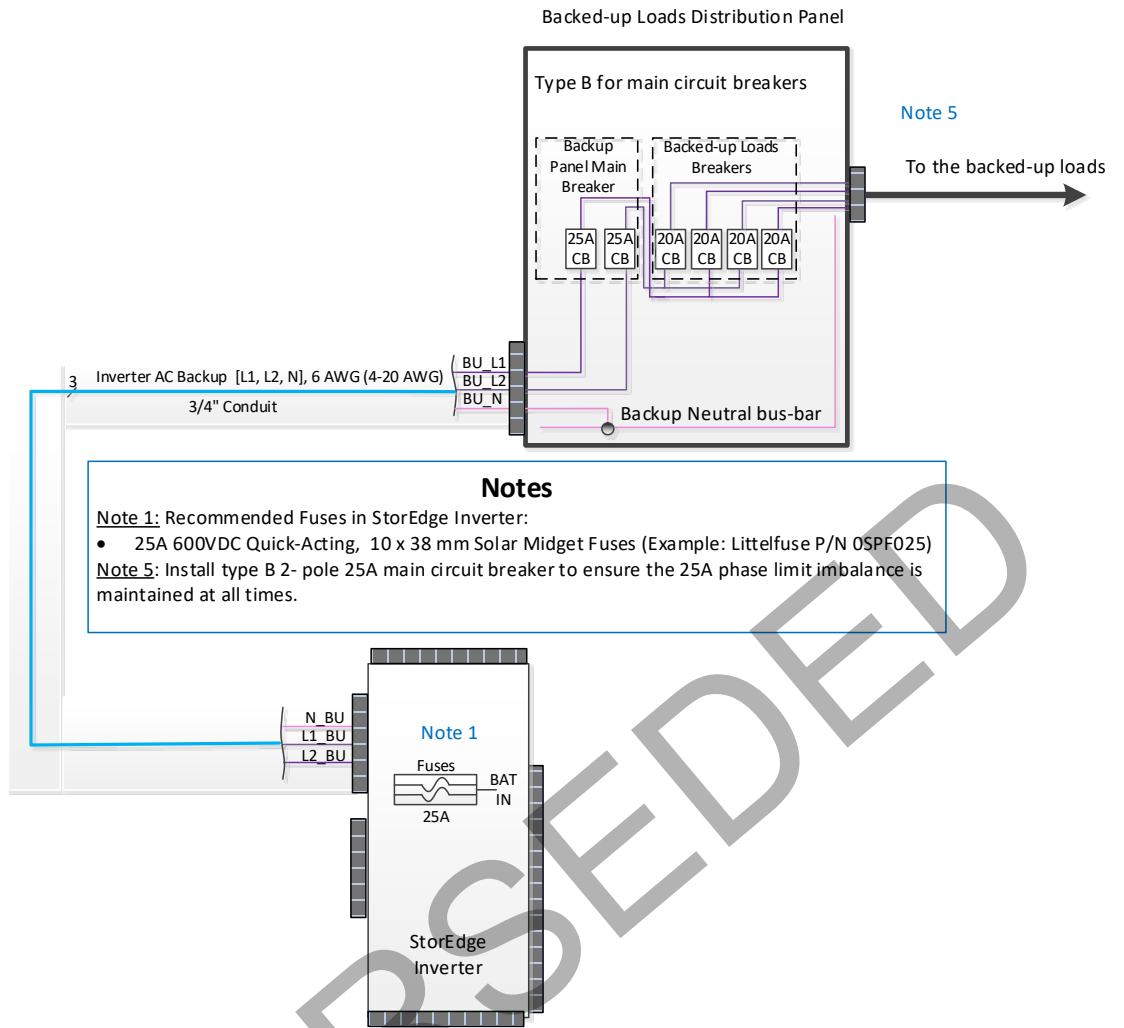
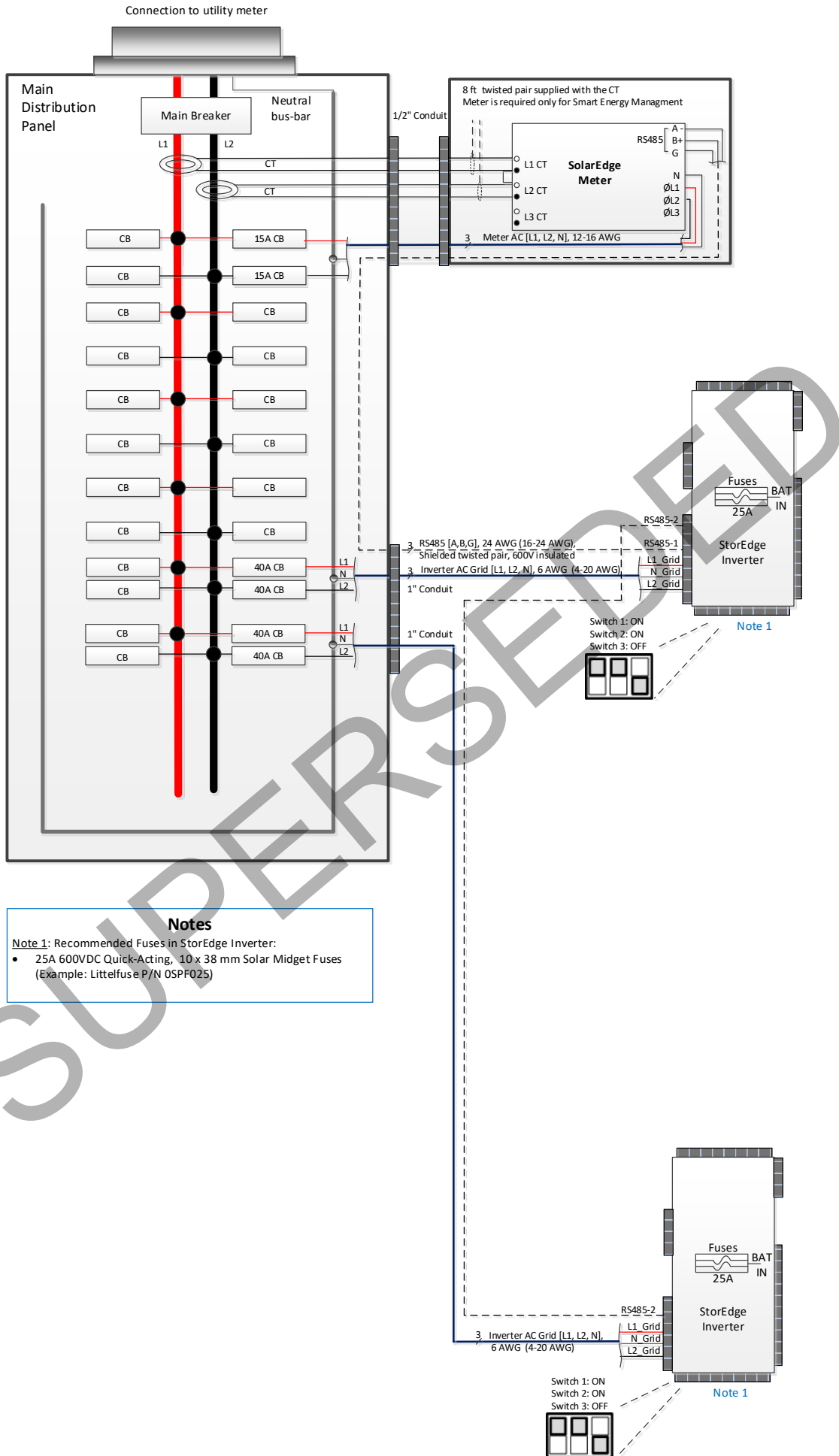

Figure 37: Basic 2-Inverter, 2-Battery Configuration – StorEdge Inverter and Backed-up Loads Distribution Panel

SUPERSEDED



Notes

Note 1: Recommended Fuses in StorEdge Inverter:

- 25A 600VDC Quick-Acting, 10 x 38 mm Solar Midget Fuses (Example: Littelfuse P/N OSPF025)

Figure 38: Basic 2-Inverter, 2-Battery Configuration – StorEdge Inverter, Meter, and Main Distribution Panel

Appendix F - Powering the LG Chem Battery off and on

LG Chem batteries are available with either of the following two types of powering mechanism design:

- With the disconnect switch (requires Firmware version 3.24xx or later):

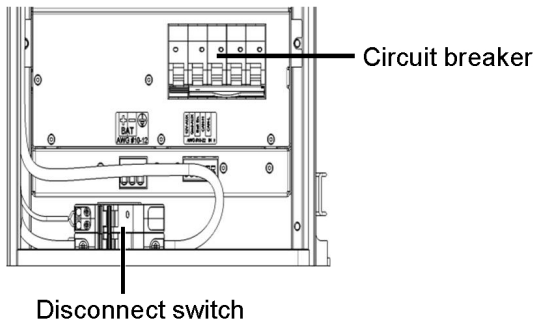

- With the auxiliary power switch:

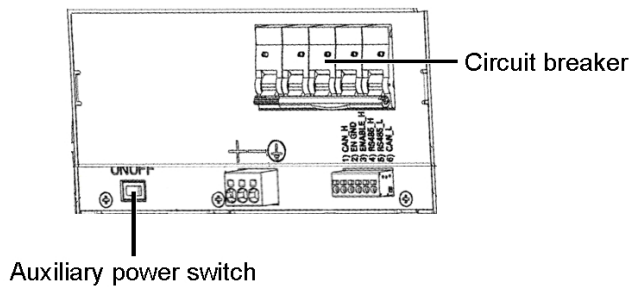

▶ To power off the battery:

- Turn off the circuit breaker.
- Turn off the disconnect/auxiliary power switch.

▶ To power the battery back on:

- Turn on the disconnect/auxiliary power switch.
- Turn on the circuit breaker.

SUPERSEDED

SolarEdge Support Contact Information

If you have technical queries concerning our products, please contact us:

USA and Canada (+1)	510 498 3200 (extension 2)	ussupport@solaredge.com
Worldwide (+972)	(0)73-2403118	support@solaredge.com

SUPERSEDED