



# Communication Board Replacement in Three Phase Inverters

## Kit Contents

- Communication board

## Required Tools

- 5mm hex key
- Torque Philips screwdriver
- 3mm flat screwdriver

## Removing the Inverter Cover

If the inverter cover is not already removed, use the following procedure for cover removal.

### → To remove the inverter cover

1. Turn the inverter ON/OFF/P switch to OFF. Wait 5 minutes for the capacitors to discharge.
2. Turn the Safety Switch (if applicable) to OFF.
3. Disconnect the AC to the inverter by turning OFF the circuit breakers on the distribution panel.
4. Unscrew the six screws, with which the inverter cover is fastened, and remove the inverter cover.



### CAUTION!

When removing the inverter cover, make sure not to damage the internal components. SolarEdge will not be held responsible for any components damaged as a result of incautious cover removal.

## Replacing the Communication Board

### → To remove the communication board:

1. Disconnect the following cables from the communication board:



### NOTE

It is recommended to take a picture of the communication board before disconnecting any cables from it. This will help you reconnect the cables correctly after reinstalling the board.

- RS485
- Ethernet
- ON/OFF/P switch
- LEDs
- Connection board

If any other cables or connections are present, disconnect them as well.

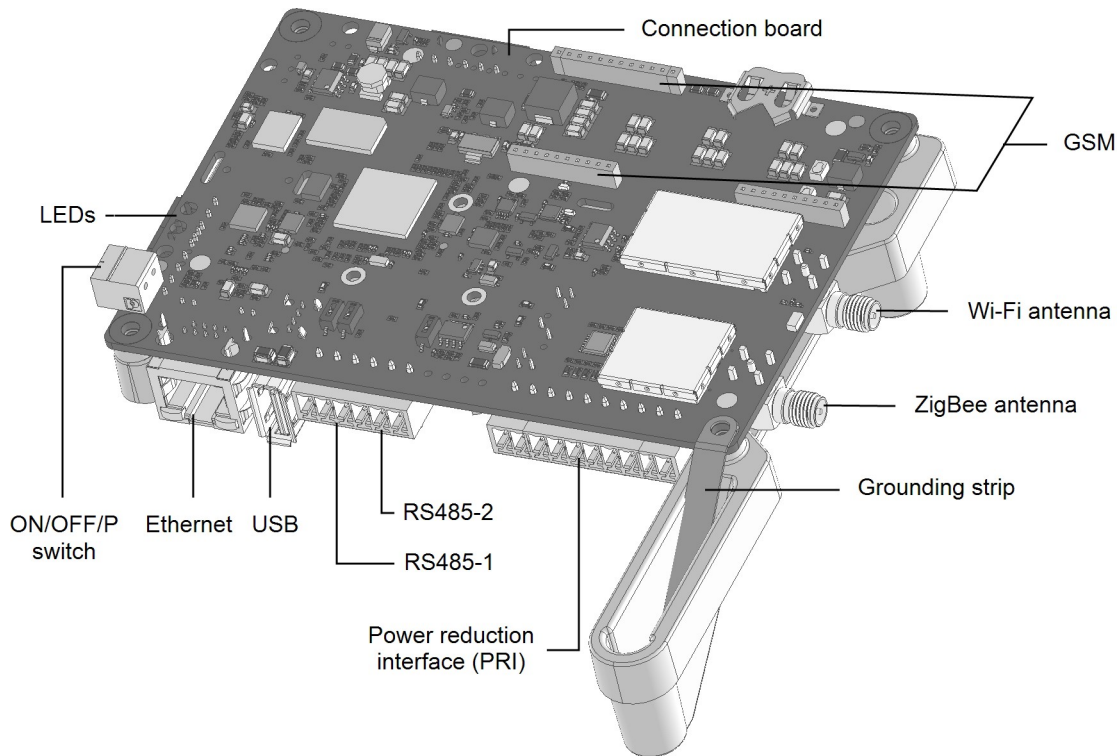

2. Unscrew the four corner screws attaching the communication board to the adapter on which the communication board is assembled. Note that a grounding strip is positioned over the communication board.
3. Remove the communication board.

→ **To install the replacement communication board:**

1. Place the communication board on the adapter.
2. Position the grounding strip over the communication board, as shown below.

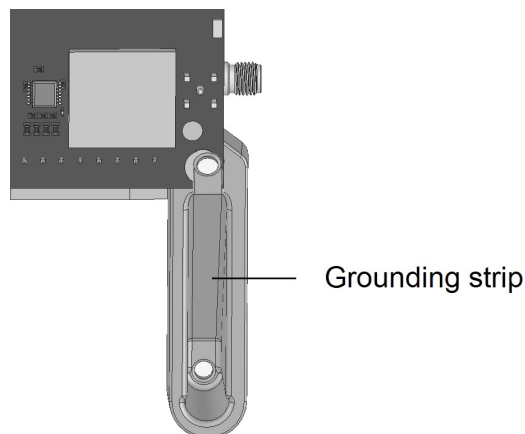

3. Fasten the communication board to the adapter with the four screws. Fasten all screws with a torque of 1.3 N\*m (12 lb\*in).
4. Reconnect the cables and connectors previously disconnected from the communication board.