

Application Note: Circuit Breaker Ratings for Three Phase Inverter with Synergy Technology for Israel

Revision History

■ Version 1.0 May 2022: release

Introduction

Inverters should be protected by circuit breakers. This document describes how to determine which circuit breaker to use in three phase commercial installations.

Using Transformers in Commercial Three Phase Inverter Installations

Using transformers in a commercial installation is optional. In most cases, a transformer is used to connect the installation to the medium voltage power grid.

For an example of how to connect a transformer to a medium voltage power grid, refer to:

- [Medium Voltage Transformer Connection of Commercial Systems, North America](#)
- [Medium Voltage Transformer Connection of Commercial Systems](#)

The following figure illustrates a typical transformer and commercial three phase inverter installation topology.

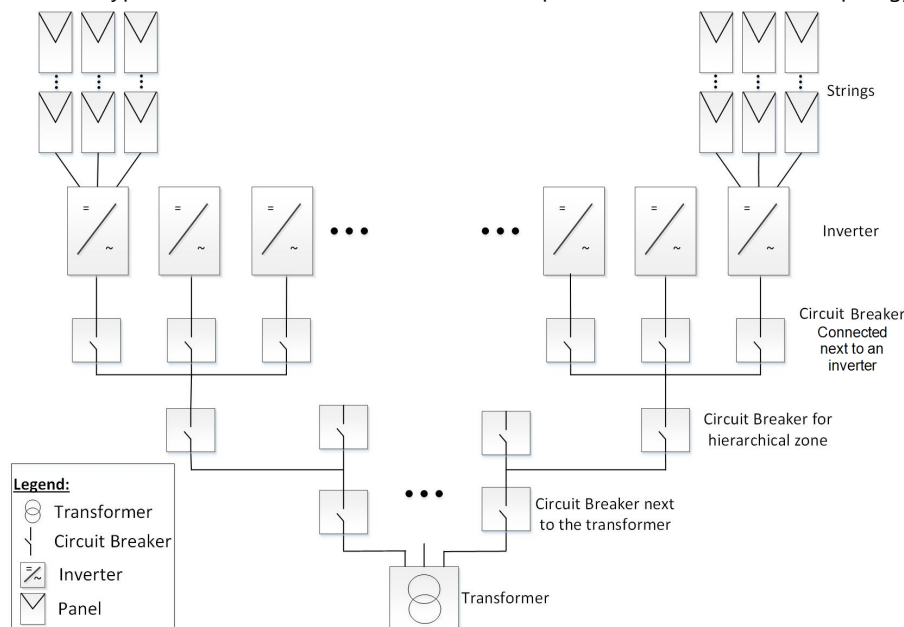

Figure 1: Typical transformer and commercial three phase inverter installation topology

There are many considerations for selecting the suitable transformer and its associated current limiting devices such as circuit breakers and fuses.

The considerations must include at least the following:

- The transformer should be designed for a typical PV system production profile: high daytime loads with no loads at night.
- The current limiting devices should protect the electrical circuits and the inverters from the excess current created by an overload, or a short circuit. If a short circuit or other overcurrent occurs, the current limiting devices should block the current flow to the circuit, thus preventing damage to the electrical circuits and the inverters.

The circuit breakers and the fuses should comply with the transformer manufacturer recommendations and with the relevant sections in standards such as IEC 60909, IEC 60364, UL 508A and NEC 2017.

Some manufacturers provide detailed information about the transformer short circuit calculation procedure, and its effect on the selection of circuit breakers and fuses at the different hierarchical levels of the installation topology (see *Figure 1*).

For an example of a calculation, refer to:

- [Guidelines on the Short Circuit Current Rating for Industrial Control Panels](#)
- [Short-circuit current rating \(SCCR\) of industrial control panels](#)

- To ensure that the circuit breaker and fuses trip as expected, follow their manufacturers' recommendations, especially with respect to the various de-rating considerations.

Determining the Rating and Rated Short-circuit Breaking Capacity of a Circuit Breaker Connected Next to an Inverter

This section explains how to determine the rating and rated short-circuit breaking capacity of a circuit breaker connected directly next to an Inverter. *Figure 1* shows an example of a circuit breaker connected next to an inverter.

Before determining the circuit breaker rating and rated short-circuit breaking capacity, the following parameters should be obtained:

- The inverter's maximum continuous output current, as shown in the datasheet
- The factor for the country of installation. This factor is determined by regulation, applicable standards, or common practice and is usually set to 1.25
- Fault current contribution from all sources
- The prospective phase to phase, phase to neutral and phase to ground short circuit current

→ To determine the rate of a circuit breaker of an inverter:

1. Multiply the maximum continuous output current of the inverter by the factor. For example: 40A x 1.25= 50A.
2. Round up the rated size, as calculated in step 1, to the closest standard circuit breaker size. For standard sizes suitable for the inverter, refer to Circuit Breaker Criteria tables shown below.

NOTE

If the result has a decimal fraction smaller than 0.5, round it down. To ensure that the selected circuit breaker trips as expected, at minimum, consider the following:



- The circuit breaker rated Voltage and current
- Temperature de-rating due to proximity to other circuit breakers and the effect of ambient temperature on the distribution board.
- De-rating due to permanent load.

If the de-rated current of the selected circuit breaker is lower than the maximum output current of the inverter, consider selecting a circuit breaker that is designed for a higher rated current, or reducing the temperature de-rating effect by increasing the distance between adjacent circuit breakers.

→ To determine the rated short-circuit breaking capacity of an inverter circuit breaker:

1. Select a circuit breaker with a rated short-circuit breaking capacity to interrupt the prospective short circuit current. Use IEC 60909-0:2016 for the calculation of prospective short-circuit currents.
2. Select and/or set the circuit breaker instantaneous trip threshold to be between 2 to 5 times the inverter's maximum continuous output current. Once the threshold is crossed, make sure that the circuit breaker interrupts the current in no more than 100ms.
3. The previous circuit breaker instantaneous trip set threshold should be lower than the prospective phase to phase, phase to neutral, and phase to ground short circuit current.

NOTE



- Make sure to select cables that are suitable for the environmental conditions, operating Voltage, current, and the selected circuit breaker
- Three or four-pole circuit breakers are required. It is recommended to use a four-pole circuit breaker when applicable
- Use a circuit breaker with a current limit rating

Table 1 and *Table 2* describe the circuit breaker criteria. Note the table may not cover all inverters. For more information related to selecting circuit breakers, refer to the Inverter datasheet.

Table 1: Inverter circuit breaker criteria for 380/400 L-L Grid

Inverter	Max. Continuous Output Current (per phase)	Recommended Circuit Breaker Rating	Max Circuit Breaker Rating
SE50K	72.5A	100A	250A
SE55.5K	80A	100A	250A
SE66.6K	96.5A	125A	250A

Inverter	Max. Continuous Output Current (per phase)	Recommended Circuit Breaker Rating	Max Circuit Breaker Rating
SE75K	120A	150A/160A	250A
SE82.8K	120A	150A/160A	250A
SE90K	130.5A	160A/175A	250A
SE100K	145A	200A	250A

Table 2: Inverter circuit breaker criteria for 480 L-L Grid

Inverter	Max. Continuous Output Current (per phase)	Recommended Circuit Breaker Rating	Max Circuit Breaker Rating
SE66.6K	80A	100A	250A
SE80K	96.5A	125A	250A
SE100K	120A	150A	250A
SE120K	145A	200A	250A

Support Contact Information

If you have technical problem concerning SolarEdge product, please contact us at:

<https://www.solaredge.com/service/support>

<https://www.solaredge.com/us/service/support>

Before contacting, make sure to have the following information at hand:

- Model and serial number of the product in question.
- The error indicated on the product SetApp mobile application, LCD screen, indication LEDs or in the monitoring platform (if available).
- System configuration information, including the type and number of modules connected and the number and length of strings.
- The communication method to the SolarEdge server (if available).

Copyright © SolarEdge Inc.

All rights reserved. May 2022.

Subject to change without notice.